

## COURSE INTRODUCTION

Welcome again to the IIT Basic Hydraulics Interactive Computer Based Training Course. This course has been designed to give you a broad based understanding of the most important hydraulic concepts. Upon completion of this course, you should understand various basic physics laws as they apply to fluid power, as well as understand schematics and system design. You will also study the various components found in a typical hydraulics system and how these components function and interact with each other.

From this main menu, you can select from any of the course topics listed on the right hand side of your screen. Although you can work through these topics in any order, we recommend that you start at the top of the list with Fluid Power Physics and continue through the subjects from top to bottom. These topics are presented in this order to aid in your understanding of the material presented. While using this program, you can return to the main menu screen at any time.

The interactive nature of this program will allow you to study and learn at your own pace. You will also find it helpful to review this information from time to time, even after you've completed the course.

This manual serves as a supplement to the CD. This manual includes:

- Notes
- Additional applications
- Expanded formulas
- Added Quiz questions

This manual is located on the Web Portal at [www.fluidpowerzone.com](http://www.fluidpowerzone.com)

Note: Answers to most quiz questions are found under each quiz section on the CD. A **Post Test** is given in the [e-learning](http://www.fluidpowerzone.com) section at [www.fluidpowerzone.com](http://www.fluidpowerzone.com)



## FLUID POWER PHYSICS

### Introduction

After completing the lessons and exercises in this section you will better understand the basic physics principles that govern fluid power. These principles are timeless and understanding them well will provide you with a solid foundation on which to learn much more about fluid power.

### Energy

As we begin our study of basic hydraulics we must first recognize that fluid power is another method of transferring energy. This energy transfer is from a prime mover, or input power source, to an actuator or output device. This means of energy transfer, although not always the most efficient, where properly applied may provide optimum work control. Energy may be defined as the ability to do work.



**Work:** Work is defined as force through distance. If we move 1000 pounds a distance of 2 feet we have accomplished work. We measure the amount of work in foot-pounds. In our example, we have moved 1000 pounds 2 feet or have accomplished 2000 foot-pounds of work.

**Power:** Power may be defined as the rate of doing work, or work over time and seconds. If we lift 1000 pounds 2 feet in 2 seconds we have accomplished 1000 units of power, or  $1000 \times 2$  divided by 2 seconds. To give us relative meaning for measuring power, we must convert this to horsepower which is a unit of measuring energy.



## NOTES

---

*Hydraulics is a means of power transmission.*

*Work (in • lbs) = force (lbs) x distance (in)*

*Power =  $\frac{\text{Force} \times \text{Distance}}{\text{Time}}$*

*Important:*

*As all systems are less than 10% efficient and efficiency factor must be added to the calculated input horsepower.*

*Example:*

*Input hp =  $\frac{10 \text{ gpm} \times 1500 \text{ psi}}{1714 \text{ (constant)}} = \frac{8.75 \text{ hp}}{0.85 \text{ (efficiency)}} = 10 \text{ hp}$*

*Rule of thumb: 1 gpm @ 1500 psi = 1.0 input hp*

**Horsepower:** Mathematically, hydraulic horsepower is expressed as follows: horsepower equals flow, in gallons per minute (gpm), times pressure, inch-pounds per square inch (psi), divided by 1714, a constant. In our illustration we are lifting 10,000 pounds (this is our force) a distance of 1 foot (this is the work to be accomplished). If we lift our load in 2 seconds we have defined a power requirement. This may be expressed as hydraulic horsepower. To lift our 10,000 pounds a distance of one foot in 2 seconds we must have a required flow rate at a specific pressure, based on cylinder size and the pump flow discharge. In this illustration a 10 gpm pump is required to extend the cylinder in 2 seconds. The pressure requirement to lift the 10,000 pounds is 1500 psi. Based on our formula our theoretical horsepower requirement would be 8.75.

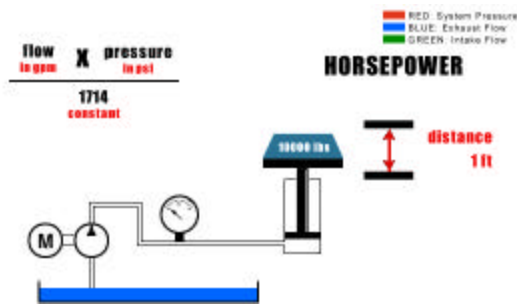

**Heat:** The law of conservation of energy states that energy can neither be created nor destroyed, although it can change its form. Energy in a hydraulic system that is not used for work takes the form of heat. For example, if we have 10 gpm going through a relief valve which has a pressure setting of 1500 psi, we can calculate the energy being converted to heat.

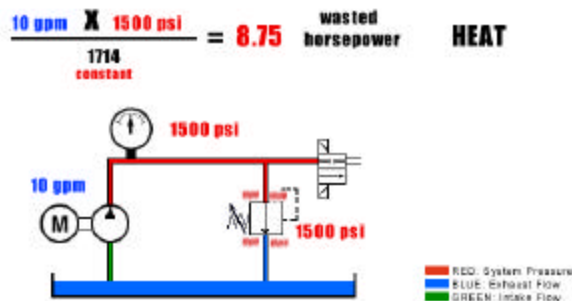

## NOTES

---

**Torque:** Torque is twisting force. It is also measured in foot-pounds. In this illustration we are producing 10 foot-pounds of torque when we apply 10 pounds of force to a 1 foot-long wrench. This same theory applies to hydraulic motors. Hydraulic motors are actuators that are rated in specific torque values at a given pressure. The twisting force, or torque, is the generated work. A motor's rotations per minute (rpm) at a given torque specifies our energy usage or horsepower requirement.

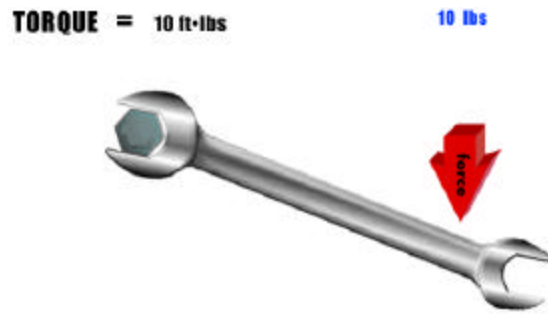

### Quiz

1. If a 500 pound weight is moved 2 feet, 1000 foot-pounds of work has been accomplished.
  - a) True
  - b) False
2. Power is defined as the rate of doing work.
  - a) True
  - b) False
3. Wasted energy in a hydraulic system
  - a) makes the system more efficient.
  - b) is destroyed.
  - c) is changed to heat.
  - d) is used to do work.

## NOTES

---

*1 hp = 33,000 ft • lbs/min or 33,000 lbs raised 1 ft in 1 min*

*1 hp = 746 W*

*1 hp = 42.4 Btu/min*



## Formulas

### Energy Formulas

$$1 \text{ Kw} = 1.3 \text{ hp}$$

$$1 \text{ hp} = 550 \text{ ft} \cdot \text{lbs/s}$$

$$\text{Hydraulic hp} = \frac{\text{gpm} \times \text{psi}}{1714}$$

$$\text{Torque (in} \cdot \text{lbs)} = \frac{\text{psi} \times \text{disp. (in}^3\text{/rev)}}{6.28}$$

$$\text{Torque (in} \cdot \text{lbs)} = \frac{\text{hp} \times 63025}{\text{rpm}}$$

$$\text{hp} = \frac{\text{Torque (ft} \cdot \text{lbs)} \times \text{rpm}}{5252}$$

$$\text{Btu (per hour)} = \Delta\text{psi} \times \text{gpm} \times 1.5$$

## NOTES

---

*To determine the volume (in<sup>3</sup>) required to move a piston a given distance, multiply the piston cross sectional area (in<sup>2</sup>) by the stroke (in).*

$$\text{Volume} = A \times L$$

*The speed of a cylinder piston is dependent upon its size (piston area) and the flow rate into it.*

$$\text{Velocity (in/min)} = \frac{\text{Flow (in}^3\text{/min)}}{\text{Area (in}^2\text{)}}$$

## Flow

Flow in a hydraulic system is produced from a positive displacement pump. This is different from a centrifugal pump, which is not positive displacement. There are three important principles that must be understood relating to flow in a hydraulic system.

Principle one: Flow makes it go. For anything to move in a hydraulic system the actuator must be supplied with flow. This cylinder is retracted. It can extend only if there is flow into port B. Shifting the directional control valve will send flow to either extend or retract the cylinder.

Principle two: Rate of flow determines speed. Rate of flow is usually measured in gpm or lpm. Gpm is determined by the pump. Changes in pump output flow will change the speed of the actuator.

Principle three: With a given flow rate, changes in actuator volume displacement will change actuator speed. With less volume to displace, the actuator will cycle faster. For example, there is less volume to displace when we retract, because the cylinder rod occupies space, diminishing the volume to be displaced. Notice the difference in speed between extend and retract.

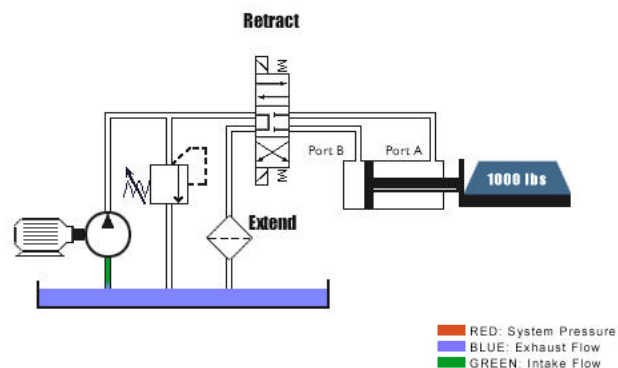

## Quiz

1. Changing the flow rate to an actuator will have no affect on the actuator speed.
  - a) True
  - b) False
2. If a cylinder is replaced with a larger diameter cylinder, the speed at which the new cylinder extends and retracts will:
  - a) not change.
  - b) increase.
  - c) decrease.

## NOTES

---

## Formulas

### Flow Formulas

$$1 \text{ gal} = 231 \text{ in}^3$$

$$\text{Cylinder Volume displaced (in}^3\text{)} = \text{Stroke} \times \text{Effective Area}$$

$$\text{Cylinder Speed (ft/min)} = \frac{\text{gpm} \times 19.25}{\text{Effective Area (in}^2\text{)}}$$

$$\text{gpm (theoretical)} = \frac{\text{Pump rpm} \times \text{in}^3/\text{rev}}{231}$$

$$\text{Volume required (gpm)} = \frac{\text{Volume Displaced} \times 60}{\text{Time (s)} \times 231}$$

$$\text{Volume Required (Hyd. Motor)} = \frac{\text{rpm} \times \text{disp. (in}^3\text{)}}{231}$$

## NOTES

---

**Note:** *Hydraulic fluids are slightly compressible, however, for simplicity we will consider them to be non-compressible*

## Pressure

Pressure in a hydraulic system comes from resistance to flow. To further illustrate this principle, consider the flow produced from a hydraulic pump. The pump is producing flow, not pressure. However, if we begin to restrict the flow from the pump, pressure will result.

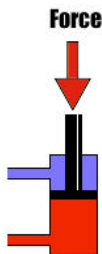
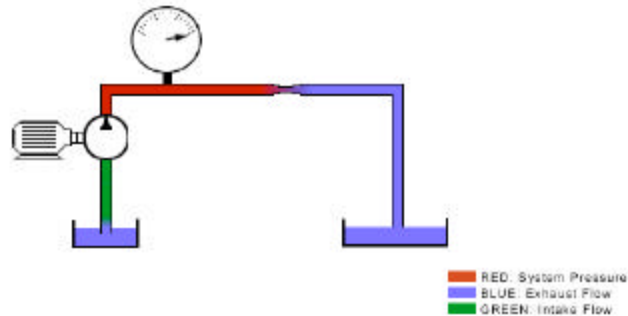

This resistance to flow is load induced from the actuator and also generated as the fluid is passed through the various conductors and components. All points of resistance, such as long runs of pipe, elbows, and various components, are accumulative in series and contribute to total system pressure.

Pascal's law forms the basis for understanding the relationship between force, pressure, and area. The relationship is often expressed with the following symbol:

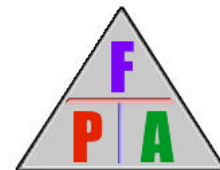

Mathematically we express this relationship as: Force is equal to pressure times area; pressure is equal to force divided by area; and we can calculate the area by dividing force by pressure.

Pascal's law is expressed as follows: Pressure applied on a confined fluid at rest is transmitted undiminished in all directions and acts with equal force on equal areas and at right angles to them. In the following illustration we have a vessel filled with a non-compressible liquid. If 10 pounds of force is applied to a 1 square inch stopper, the result would be 10 pounds of force on every square inch of the container wall. If the bottom of the container was 20 square inches total, the result in force would be 10 psi times 20 square inches, or 200 pounds of total force, since force equals pressure times area.

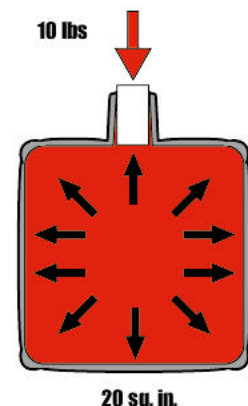

## NOTES

---

*The force (lbs) exerted by a piston can be determined by multiplying the piston area (in<sup>2</sup>) by the pressure applied (psi).*

*To find the area, square the diameter and multiply by 0.7854*

$$A = d^2 \times 0.7854 \text{ or } d = \sqrt{A / 0.7854}$$



## Load-Induced

Load-induced pressure is defined as pressure generated from the load, or force on the actuator. The effective area of the cylinder piston is the area available for force generation. In our illustration a 10,000 pound force gives us a load-induced pressure of 1,000 psi, based on our formula. When the cylinder is extended, the required pressure to move the 10,000 pound load is 1,000 psi less frictional forces.

During retraction, the effective area is only 5 square inches. This increases the required pressure to 2,000 psi needed to retract the load.

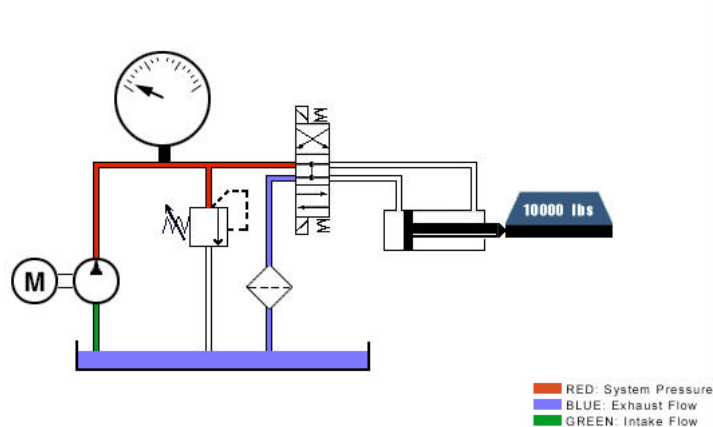

## Pressure Drop

Pressure that is not directly used to provide work may be defined as pressure drop or resistive pressure. It is the pressure required to push the fluid through the conductors to the actuator.

This energy takes the form of heat. Excessive pressure drop may contribute to excessive heat build up in the hydraulic system. This resistive pressure is accumulative and must be added to the overall system pressure requirements.

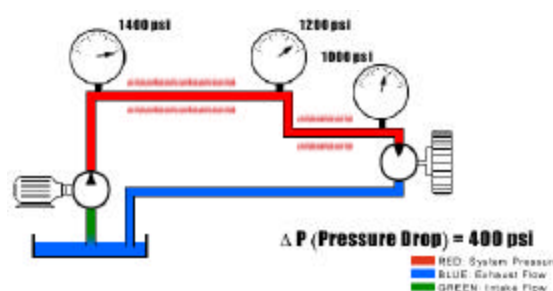

## NOTES

---

## Quiz

1. Increasing the load on an actuator will cause a decrease in system pressure.
  - a) True
  - b) False
2. Pressure is a result of flow.
  - a) True
  - b) False
3. Pressure is measured in in/lbs.
  - a) True
  - b) False

## Formulas

### Pressure Formulas

$$1 \text{ Bar} = 14.5 \text{ psi}$$

$$\text{psi} = \frac{\text{lbs}}{\text{in}^2} = \text{Pounds per square inch}$$

---

$$\text{Force (lbs)} = \text{Pressure (psi)} \times \text{Area (in}^2\text{)}$$

$$\text{Pressure (psi)} = \frac{\text{Force (lb)}}{\text{Area (in}^2\text{)}}$$

$$\text{Area (in}^2\text{)} = \frac{\text{Force (lb)}}{\text{Pressure (psi)}}$$

---

$$\text{Area} = d^2 \times 0.7854$$

## NOTES

---

***Hydraulic fluid types vary according to applications. The four most common types are:***

- 1. Petroleum base – most common and best appellation where fire resistance is not required.*
- 2. Water glycol – used where a fire resistance fluid is required. Most pumps must be de-rated or require special bearings when using water glycol.*
- 3. Synthetic – used where applications require fire resistance or nonconductivity. Synthetic fluids are typically not compatible with most common seal components.*
- 4. Environmentally friendly – fluids that will have a minimal effect on the environment in the event of a spill.*

*Hydraulic fluids are slightly compressible. The amount of compressibility depends on the type of fluid. For this training program we will consider fluids to be basically non-compressible.*

# Fluids

## Overview

The study of fluid power deals with understanding energy transmission through a confined liquid. The hydraulic fluid may well be considered the most important component in a hydraulic system. It serves as lubricant, heat transfer medium, as well as a means of transferring energy, and as a sealant.

### Lubricant

Fluid as lubricant allows this block to glide with less friction and wear on the parts.



### Heat Transfer

The heated fluid enters and radiates its energy out and leaves cooled.

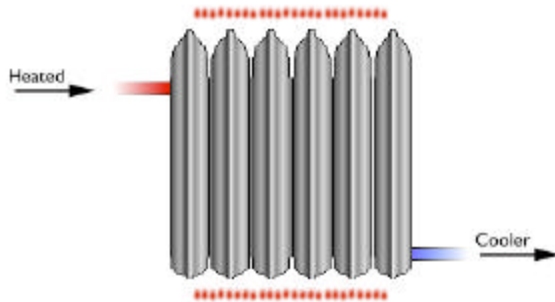

### Energy Transfer

Fluid will transfer energy from the input side to the output side because fluid is basically incompressible.



### Sealant

The fluid between the wall and piston will act as a sealant because of its low viscosity.

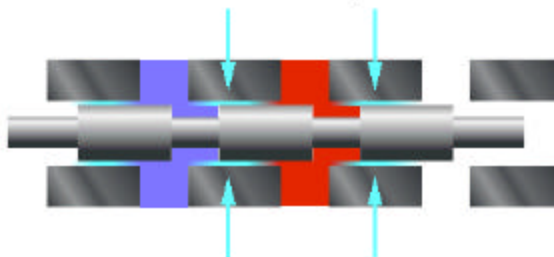

## NOTES

---

### ***Maximum Recommended Oil Velocity in Hydraulic Lines:***

- *Pump suction line 2-4 ft/s*
- *Pressure lines 500 psi 10-15 ft/s*
- *Pressure lines 3000 psi 15-20 ft/s*
- *Pressure lines over 3000 psi 25 ft/s*

*The most important characteristic of fluid is its viscosity.*

Hydraulic fluid is basically non-compressible and can take the shape of any container. Because of this, it exhibits a certain advantage in the transmission of force. These are examples where the fluid will take the shape of a container.



Using a positive displacement pump we transmit energy from the prime mover, (our input source), to the actuator, (our output), through the medium of a non-compressible fluid. As the fluid passes through the conductors and components, certain considerations must be given to ensure maximum efficiency of energy transfer. These considerations include the understanding and proper application of fluid velocity and viscosity.

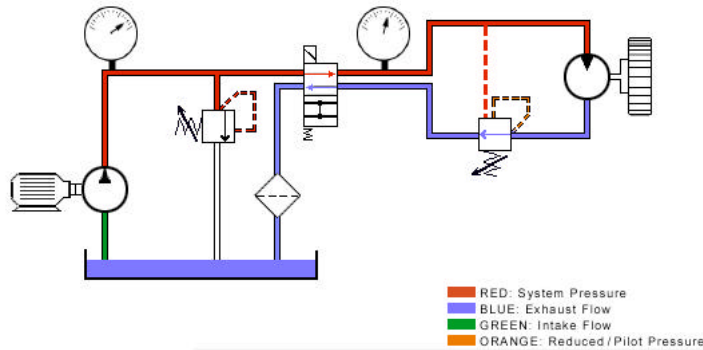

## Velocity

Velocity is the distance fluid travels per unit of time. With a fixed volume of fluid going through a conductor, the velocity of the fluid will depend upon the inside diameter of the conductor.

If the diameter of a conductor is increased, the velocity of the fluid will decrease. Conversely, if the diameter of the conductor is decreased, the fluid's velocity will increase.

$$\text{Velocity} = \frac{\text{gpm} \times 0.3208}{\text{Inside Diameter}^2 \times 0.7854}$$

## NOTES

---



To better illustrate this principle we have two simple systems in which two pumps of equal displacement of 30 gpm move fluid through conductors of different sizes. The displacement remains equal while the velocity of the fluid varies with the size of the conductor. The fluid turning fly wheel 2 is moving 4 times faster than the fluid turning fly wheel 1 because the inside diameter of the pipe for fly wheel 1 is twice the size of the inside diameter of fly wheel 2. However, the fly wheels turn at the same rate because the volume displacement is equal in both systems.

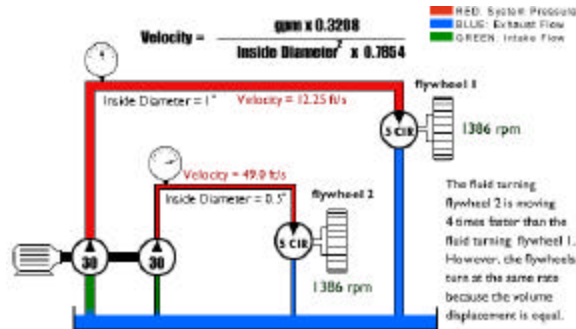

## Viscosity

Viscosity is a measure of a liquid's resistance to flow. A thicker fluid has more resistance to flow and a higher viscosity. Viscosity is affected by temperature. As a hydraulic fluid's temperature increases, its viscosity or resistance to flow decreases.

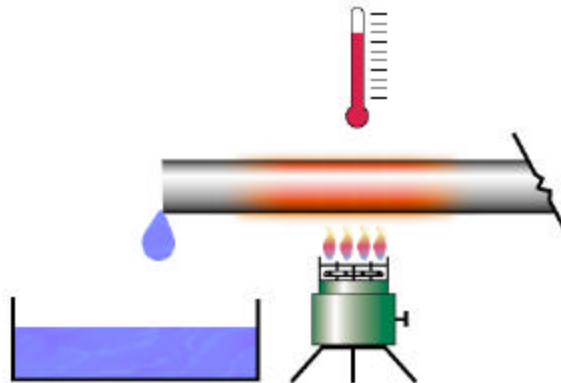

## NOTES

---

***The following applies to petroleum based hydraulic fluids.***

*Hydraulic oil serves as a lubricant and is practically non-compressible. It will compress approximately 0.5% at 1000 psi.*

*The weight of hydraulic oil may vary with a change in viscosity, however, 55 to 58 lbs/ft<sup>3</sup> covers the viscosity range from 150 SUS to 900 SUS @ 100 degrees F.*

*Pressure at the bottom of a one foot column of oil will be approximately 0.4 psi. To find the pressure at the bottom of any column of oil, multiply the height in feet by 0.4.*

*Atmospheric pressure equals 14.7 psia at sea level.*

*psia (pounds per square inch absolute).*

*Gauge readings to not include atmospheric pressure unless marked psia.*

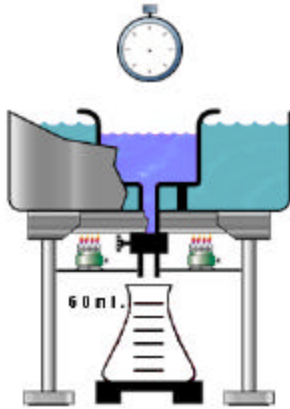

A viscometer, the device used to measure a liquid's viscosity, consists of a small reservoir surrounded by a water bath used to heat and maintain the liquid at a constant temperature. There is a small orifice below the reservoir through which the liquid can pass once it is heated to a specified temperature. A stop watch is used to determine how much time it takes to fill a 60 milliliter flask. The number of seconds that it takes to fill the flask at a given temperature is the liquid's viscosity at that temperature.

### Quiz

1. Viscosity is affected by the diameter of the fluid conductor.
  - a) True
  - b) False
  
2. At a given flow rate, to increase the diameter of the fluid conductor would cause the fluid's velocity to increase.
  - a) True
  - b) False
  
3. Pressure drop in a fluid conductor is due to leakage.
  - a) True
  - b) False

### Formulas

#### Fluids Formulas

$$\text{Flow rate (gpm)} = \frac{\text{Velocity (ft/s)} \times \text{Area (in}^2\text{)}}{0.3208}$$

$$\text{Conductor area (in}^2\text{)} = \frac{\text{gpm} \times 0.3208}{\text{Velocity (ft /s)}}$$

$$\text{Fluid Velocity (ft/s)} = \frac{\text{gpm} \times 0.3208}{\text{Area}}$$

## NOTES

---

*Fluid is pushed on drawn into a pump*

*Pumps do not pump pressure, their purpose to create flow. (Pressure is a result of resistance to flow).*

*To determine the required pump capacity:  $gpm = \frac{\text{speed (rpm)} \times \text{disp (in}^3/\text{rev)}}{231}$*

## PUMPS

### Introduction

Although various types of hydraulic pumps exist, the sole purpose of pumps is to provide flow for the hydraulic system. In this section you will learn more about the three basic types of hydraulic pumps: gear pumps, vane pumps, and piston pumps. It is important to understand the differences and similarities between these pumps, their fluid displacement capabilities, and their proper application in a hydraulic system.

### Gear Pumps

Pumps are fluid power components which transform mechanical energy transmitted by a prime mover into fluid power energy. Gear pumps are compact, relatively inexpensive, and have few moving parts. External gear pumps consist of two gears, usually equal in size, that mesh with each other inside a housing. The driving gear is an extension of the drive shaft. As it rotates, it drives the second gear. As both gears rotate, fluid is drawn in through the inlet. This fluid is trapped between the housing and the rotating teeth of the gears where it travels around the housing and is pushed through the outlet port. The pump creates flow and, under pressure, transfers energy from our input source, which is mechanical, to a fluid power actuator.

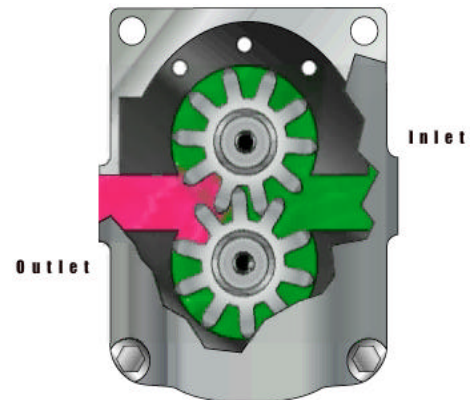

### Quiz

1. Gear pumps:
  - a) are variable volume.
  - b) are centrifugal.
  - c) have positive displacement.
  - d) are pressure compensated.
2. Gear pump displacement increases with increased input rpm.
  - a) True
  - b) False
3. Gear pumps
  - a) trap fluid between the teeth and the housing.
  - b) have many moving parts.
  - c) are used to control pressure control valves.

## NOTES

---

## Vane Pumps

### Unbalanced:

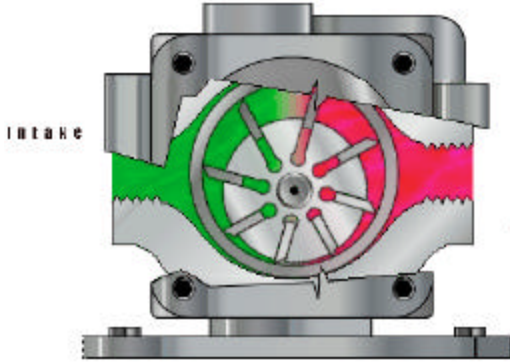

The rotating portion of the pump, or rotor, is positioned off center of the cam ring, or housing. The rotor is connected to a prime mover by means of a shaft. As the rotor is turned, the vanes are thrown out by centrifugal force and contact the ring, or housing, forming a positive seal.

Fluid enters the pump and fills the large volume area formed by the offset rotor. As the vanes push the fluid around the cam the volume decreases, and the fluid is pushed out the outlet port.

### Balanced:

In the unbalanced vane pump, which has been previously illustrated, on half of the pumping mechanism it is at less than atmospheric pressure. The other half is subjected to full system pressure. This results in side loading the shaft while under high pressure conditions. To compensate for this, the ring in a balanced vane pump is changed from circular to cam-shaped. With this arrangement, the two pressure quadrants oppose each other. Two ports intake fluid and two pump fluid out. The two intake ports and the two outlets ports are connected inside the housing. Because they are on opposite sides of the housing, excessive force or pressure buildup on one side is canceled out by equal but opposite forces on the other side. With the forces acting on the shaft balanced, the shaft side load is eliminated.

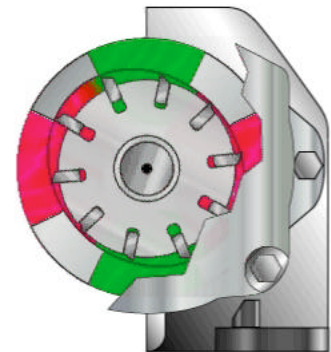

Flow is created in the same manner that you have seen illustrated in the unbalanced vane pump, the only difference being, the two discharge and two suction cavities rather than one. It is notable that constant volume, positive displacement vane pumps used in industrial systems are generally of the balanced design.

## NOTES

---



## Quiz

1. Vane pumps:
  - a) may be variable displacement.
  - b) are not positive displacement.
  - c) use a rotor for pumping.
  
2. A balanced vane pump uses an elliptical cam ring for opposing pressure quadrants.
  - a) True
  - b) False
  
3. Which is not a part of a vane pump?
  - a) Vane
  - b) Rotor
  - c) Cam Ring
  - d) Barrel

## Piston Pumps

Axial piston pumps convert rotary motion of an input shaft to an axial reciprocating motion, occurring at the pistons. This is accomplished by a swashplate that is either fixed or variable in its degree of angle. As the piston barrel assembly rotates, the pistons rotate around the shaft with the piston slippers in contact with and sliding along the swashplate surface. With the swashplate vertical, no displacement occurs because there is no reciprocating motion. As the swashplate increases in angle, the piston moves in and out of the barrel as it follows the angle of the swashplate surface. With the swashplate vertical, no displacement occurs because there is no reciprocating motion. As the swashplate increases in angle, the pistons move in and out of the barrel as it follows the angle of the swashplate.

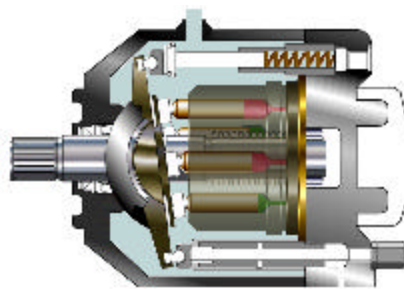

During one half of the circle of rotation, the piston moves out of the cylinder barrel and generates an increasing volume. In the other half of the rotation the piston moves into the cylinder barrel and generates a decreasing volume. This reciprocating motion draws fluid in and pumps it out.

## NOTES

---

## Quiz

1. Piston Pump
  - a) turn reciprocating motion into rotating motion.
  - b) utilize one piston only.
  - c) require a case drain.
  - d) are fixed volume only.
2. Increasing the angle of the swashplate in a piston pump
  - a) increases the pistons' displacement.
  - b) allows the pump to rotate faster.
  - c) Increases the pump's outlet pressure.
3. Axial piston pumps utilize a rotating swashplate.
  - a) True
  - b) False

## Fixed vs. Variable

There are two types of positive displacement hydraulic pumps. A fixed pump, which produces a fixed flow (gpm) based on the rpm of the prime mover or electric motor, and a variable pump, which can vary its rate of flow (gpm) while the input speed (rpm) remains constant. Although displacement is typically measured in volume displaced per revolution, output is measured in gpm.

In this example a motor turning at 1200 rpm is driving a fixed displacement gear pump producing 5 gpm flow. The flow (gpm) can be changed if the speed (rpm) of the motor changes.

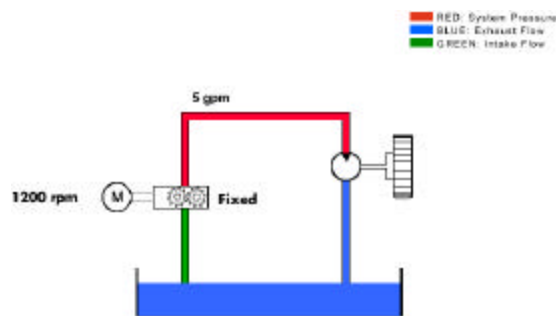

When a variable displacement pump is used in the system, the flow (gpm) can be varied in two ways. As with fixed displacement pumps, the flow (gpm) will be changed if the speed (rpm) of the motor is changed. The second way is to vary the displacement of the pump. For example, the displacement of an axial piston pump is determined by the distance the pistons are pulled in and pushed out of the cylinder barrel. Since the swashplate

## NOTES

---

angle controls this distance in an axial piston pump, we need only to change the angle of the swashplate to alter the piston stroke and pump volume. Several means of varying the swashplate angles are used. They may include hand levers, mechanical stops, or more sophisticated, hydraulically positioned devices. If the pump produces 5 gpm flow with 1200 rpm's and maximum displacement, the flow (gpm) can be varied by moving the swashplate in the upright position or de-stroking the pump. This will vary the flow from 5 – 0 gpm.

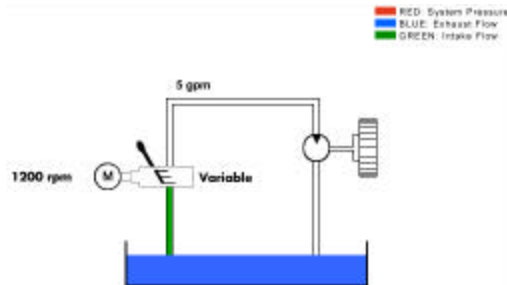

The gallon per minute discharge of fixed displacement pumps can only be changed by increasing or decreasing the speed of the electric motor.

## Quiz

1. Gear Pumps
  - a) may be variable.
  - b) are usually not used in hydraulics.
  - c) change displacement with changes in rpm.
  - d) give constant output with constant rpm.
2. Variable displacement pumps change the output flow by
  - a) changing either the pump's rpm and/or swashplate angle.
  - b) only changing the swashplate angle.
  - c) only changing the pump's rpm.
3. Variable volume pumps may also be pressure compensated.
  - a) True
  - b) False
4. Piston Pumps
  - a) increase flow by increasing the angle of the swashplate.
  - b) decrease flow with increase in swashplate angle.
  - c) are at full displacement when the rotating group is turning.

## NOTES

---

## Pressure Compensated

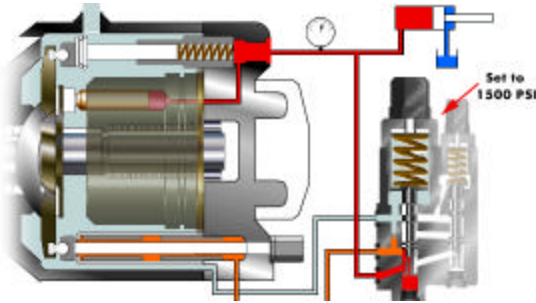

Variable volume pumps can also be pressure compensated. A pressure compensated piston pump de-strokes, or moves to zero output, at a predetermined pressure. This is accomplished by hydraulically positioning the pumping chambers to zero output while maintaining compensator pressure at the outlet of the pump. In this example we have used a pressure compensated piston pump. It is helpful to understand the functionality of a piston pump.

As the pistons rotate around the shaft and follow the angle of the swashplate, they are pumping fluid out the outlet, which provides pressure to move a component such as a cylinder. When the cylinder reaches the end of its stroke, pressure rises at the outlet of the pump as the fluids flow path is blocked.

This pressure forces the compensating spool up allowing the pressurized fluid to energize the de-stroking piston and push against the swashplate, forcing it to a vertical position. With the swashplate vertical the pump is now de-stroked and the pressure at the outlet board is maintained at a constant level. A very slight amount of flow is produced to maintain de-stroke pressure. This flow is bypassed into the case and carried back to the reservoir through the pump case drain outlet.

Of the three types of hydraulic pumps discussed, (gear, vane and axial piston), only the vane and piston may be pressure compensated.

## NOTES

---



## Quiz

1. When an axial piston pump is de-stroked or fully compensating
  - a) the swashplate is at a  $19^\circ$  angle.
  - b) the swashplate is at a  $0^\circ$  angle.
  - c) there is no pressure.
  - d) there is maximum flow.
  
2. A pressure compensated axial pump will de-stroke when flow is blocked.
  - a) True
  - b) False
  
3. When a pressure compensated pump is on stroke, the system is at rated flow and working pressure.
  - a) True
  - b) False

## NOTES

---

*Mill type cylinders are more robust in design than tie rod cylinders. Applications for the mill type cylinders include presses, cranes, iron works and rolling mills.*

# ACTUATORS

## Introduction

The actuator is the interface component that converts hydraulic horsepower back into mechanical horsepower. An actuator may either be a cylinder giving linear motion or a hydraulic motor giving rotating motion. After completing this section you should have a good understanding of how actuators work in a hydraulic system.

## Cylinders

Cylinders are linear actuators. Their output force, or motion, is in a straight line. Their function is to convert hydraulic power into linear mechanical power. Their work applications may include pushing, pulling, tilting, and pressing. Cylinder type and design are based on specific applications.

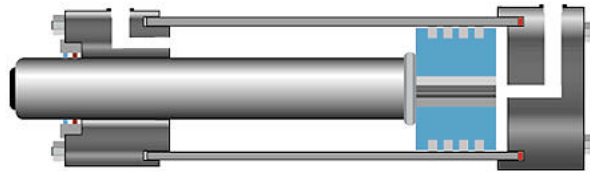

## Types

A ram is perhaps the most simple of the actuators. It has only one fluid chamber and exerts force in only one direction. It is used in applications where stability is needed on heavy loads. A single acting cylinder is pressurized on one end only. The opposite end is vented to the tank or atmosphere. They are designed so that the load or a device, such as an internal spring, retracts them.

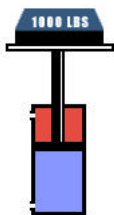

The double acting cylinder is the most common cylinder used in industrial hydraulics. We can apply pressure to either port, giving power in both directions. These cylinders are also classified as differential cylinders because of their unequal exposed areas during extend and retract. The difference in effective area is caused by the area of the rod that reduces the piston area during retraction. Extension is slower than retraction because more fluid is required to fill the piston side of the cylinder. However, more force can be generated on extension because of greater effective area. On retraction, the same amount of pump flow will retract the cylinder faster because of the reduced fluid volume displaced by the rod. Less force, however, can be generated due to less effective area.

## NOTES

---

A double rod cylinder is considered a non-differential type cylinder. The areas on both sides of the piston are equal, thus providing equal force in both directions. An application for such cylinders would be where it is advantageous to couple a load to both ends or where equal speed is needed in both directions.

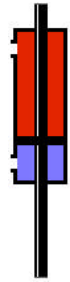

## Design

The cylinder assembly is constructed of a steel cap end head, a steel barrel assembly, a rod end head, a rod bearing, a piston, and piston rod. Tie rods and nuts are used to hold the heads and barrel assembly together. Static seals keep the joint pressure tight. A rod wiper is provided to prevent foreign material from entering the bearing and seal area. Sealing a moving surface is provided by the rod seal, which prevents fluid from leaking past the rod, and by the piston seals, which prevent fluid from bypassing the piston. Fluid is routed to and from the cylinder through the rod end port and the cap end port.

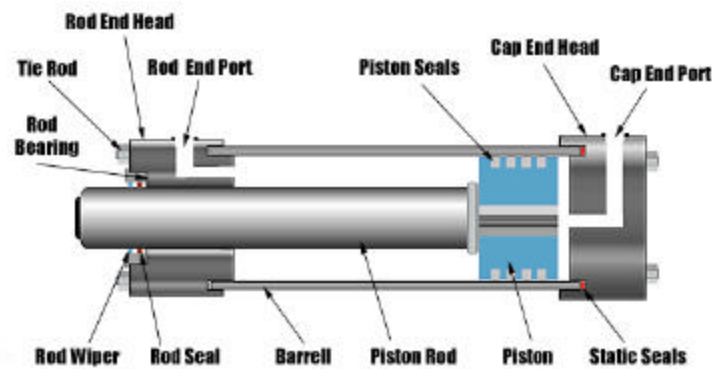

## Motors

Hydraulic motors are classified as rotary actuators. Motors very closely resemble pumps in construction. However, instead of pushing on the fluid as the pump does, the fluid pushes on the internal surface area of the motor, developing torque. Resistance from the load is encountered and pump flow provides a continuous rotating motion. Since both inlet and outlet ports may be pressurized, most hydraulic motors are externally drained.

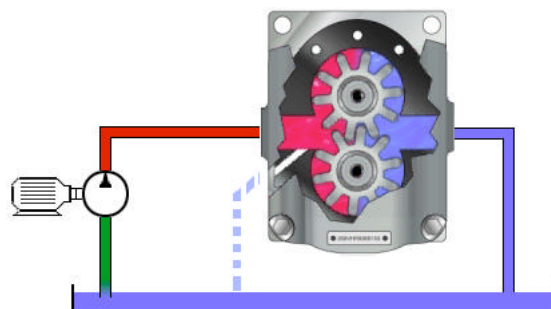

## NOTES

---

*Hydraulic motors are typically classified as high speed motors (500 – 10,000 rpm) or low speed motors (0 – 1,000) rpm.*

$$\text{Torque (in} \cdot \text{lbs)} = \frac{63025 \times \text{hp}}{\text{rpm}}$$

$$\text{hp} = \text{Torque (in} \cdot \text{lbs)} \times \frac{\text{rpm}}{63205}$$

## Types

The three most common types of hydraulic motors are the gear, vane and piston.



**Gear Motor**



**Vane Motor**

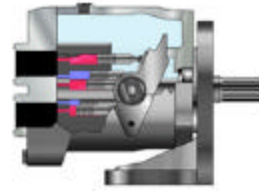

**Piston Motor**

## Application

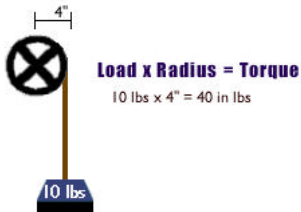

Hydraulic motors are primarily rated according to displacement and torque. The first consideration should be torque. Hydraulic motors are rated in foot or inch-pounds of torque per given psi, typically inch-pounds per 100 psi. Torque is equal to load times radius. Large displacement motors usually have a greater radius for the hydraulic fluid to push against, therefore, they create more torque at a specific pressure.

A hydraulic motor that is rated at 100 inch-pounds of force per 100 psi is rotating a winch with a diameter of 4 inches. Our load is 500 pounds. The required torque is 2000 inch-pounds. Based on the torque rating of our motor, our operating pressure would be 2000 psi. The second consideration would be displacement. This is necessary to determine the amount of flow required to rotate the hydraulic motor at the required rpm.

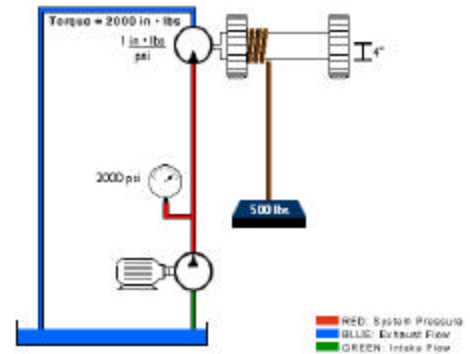

## NOTES

---



## Quiz

1. The purpose of an actuator is to convert hydraulic energy to mechanical energy.
  - a) True
  - b) False
  
2. Cylinders can be used to
  - a) push or pull a load.
  - b) tilt a load.
  - c) press.
  - d) all of the above.
  
3. At the same pressure, a cylinder will produce more force on extend than on retract.
  - a) True
  - b) False
  
4. Hydraulic motors are rated according to displacement and torque capacity.
  - a) True
  - b) False
  
5. Hydraulic motors are only built in two styles: van and piston.
  - a) True
  - b) False

## NOTES

---

### ***IMPORTANT !***

*The primary function of a pressure relief valve is to protect the system from excessive pressure. The valve should no be used to direct excess pressure to the tank, as this may cause the system to overheat.*

# PRESSURE CONTROL

## Introduction

This section is designed to give you an understanding of the basic concept of manipulating force through a hydraulic system, using pressure control valves. The two basic design types of these valves are direct acting and pilot operated. This section will illustrate the operating principles of these two types of valves.

## Overview

The primary concern in fluid power circuits is to either control the rate of flow or the pressure level. One misconception has been that pressure may be controlled with an orifice or flow control device. This is never accomplished with any degree of accuracy. For accurate control of force, six types of pressure controls have been developed. They are: relief valve, unloading valve, sequence valve, reducing valve, counterbalance valve, and brake valve. By symbol, these valves closely resemble one another. Often only their location in the hydraulic circuit will designate what type of pressure valve they are.

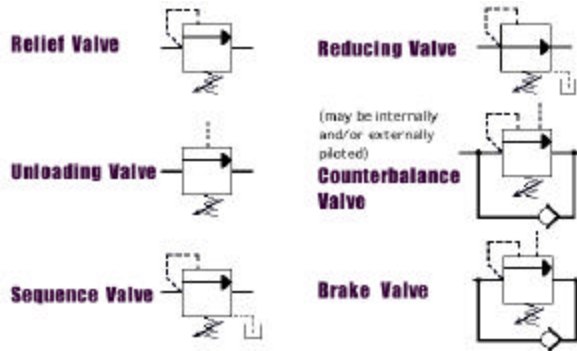

## Direct Acting Relief Valve

Maximum system pressure can be controlled with the use of a normally closed pressure valve. With the primary port of the valve connected to a system pressure and the secondary port connected to tank, the poppet is actuated by a predetermined pressure level, at which point primary and secondary passages are connected, and flow is diverted to the tank. This type of pressure control is known as a relief valve.

## NOTES

---

*High flow valves require larger springs to facilitate larger valve assemblies. Larger springs contribute to higher pressure override in the valve.*

*Pressure override is the difference between the cracking pressure and the pressure needed to completely open the valve.*

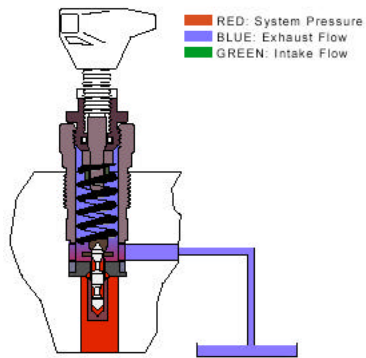

A direct acting relief valve is one in which the poppet is held closed by direct force of a mechanical spring which is usually adjustable. Spring tension is set on the knob to keep the poppet closed until system pressure working against the poppet reaches the desired cracking pressure. When the system pressure reaches full relief value, all fluid is passed across the poppet to the tank passage. It should be noted that direct acting relief valves are usually available in only relatively small sizes. Because it is difficult to design a strong enough spring to keep the poppet closed at high pressure and high flow.

### Quiz

1. The secondary port of a direct acting relief valve is connected back to the tank.
  - a) True
  - b) False
  
2. Direct acting relief valves only come in large sizes because they have to utilize a large spring directly against a poppet.
  - a) True
  - b) False
  
4. A direct acting relief valve can be used to control maximum system pressure.
  - a) True
  - b) False

### Pilot Operated Relief Valve

Pilot operated relief valves are designed to accommodate higher pressures with higher flows being confined to smaller frame size, then a direct acting relief valve with the same rate of flow capacity. The valve is built in two stages. The first stage includes the main spool held in a normally closed position by a light non-adjustable spring. The stage is large enough to handle the maximum flow rating of the valve. The second stage is a small direct acting relief valve usually mounted as a cross head on the main valve body, and includes a poppet, spring, and adjustable knob. The first stage handles full rate of flow to the tank. The second stage controls and limits pilot pressure level in the main spring chamber.

## NOTES

---

Although **pilot operated relief valves** characteristically have less pressure override **than direct acting relief valves**, their response time is slower.

**“Pressure override”** occurs when flow through the relief valve increases after the cracking pressure has been reached. Due to the compression of the spring, the pressure will rise above, or “override” the setting of the valve.

**Note:** All pressure valves are designed as either direct acting or pilot operated.

Relieving action through the main spool is as follows: As long as the system pressure is less than relieving pressure set on the control knob, pressure in the main spring chamber is the same as pump line pressure, because there is no flow through the control orifice. Consequently, there is no pressure drop from one side of the orifice to the other.

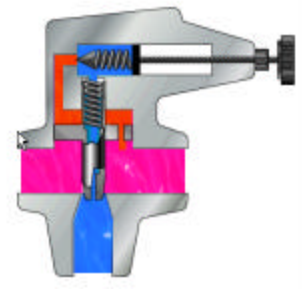

When pump line pressure rises higher than the adjustment set on the control knob the pilot relief poppet moves off its seat. This starts oil flow from the pump line, through the orifice, across the pilot relief poppet, and to the tank.

This restricted flow caused by the orifice creates a pressure difference between the pump line and the area across the pilot orifice. This pressure imbalance causes the main poppet to move off its seat. This will discharge enough of the pump flow to prevent any further rise in the pump line pressure. When pump line pressure drops below the control knob setting, the pilot relief closes, flow through the orifice ceases, and the main spring can re-seat the main poppet.

### **Poppet Relief Valve**

The pilot operated pressure relief valve comprises a valve body, a main spool cartridge, and a pilot valve with a pressure-setting adjustment.

■ RED: System Pressure  
■ BLUE: Exhaust Flow  
■ GREEN: Inlet Flow  
■ ORANGE: Reduced/Pilot Pressure

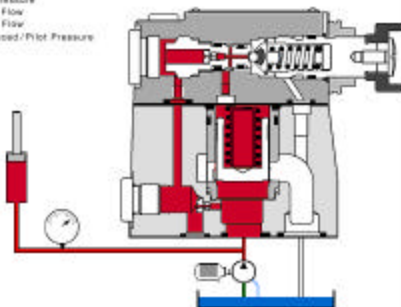

The pressure present in the primary port acts on the bottom of the main spool and, at the same time, the pressure is fed to the spring-loaded side of the main spool via the control lines and containing orifices. The pressure is also present at the ball of the pilot valve. If the pressure increases to a level above the spring setting of the pilot valve, the ball opens against the spring.

The pilot oil on the spring side of the main spool cartridge now flows into the spring chamber of the pilot valve and is directed internally to the secondary port and back to the tank.

Due to the orifices in the control line between the primary port and the pilot valve, a pressure drop, or pressure differential, exists between the bottom of the main spool and the spring side of the main spool. This pressure differential lifts the main spool off its seat and connects the primary pressure port of the valve to the secondary, or tank port.

Fluid now flows to the tank, maintaining the set operating pressure of the valve.

## NOTES

---



## Quiz

1. By design, a pilot operated relief valve has a larger flow capacity than a direct operated relief valve of the same frame size.
  - a) True
  - b) False
  
2. A pilot operated relief valve utilizes a small orifice in the main body for the purpose of creating a pressure differential across the spool when the pilot poppet is open.
  - a) True
  - b) False
  
3. The first stage of a pilot operated relief valve is actually a small direct acting relief valve.
  - a) True
  - b) False

## NOTES

---

## Pressure Sequence

A sequence valve is a normally closed pressure control valve that insures that one operation will occur before another, based on pressure. In our clamp and drill system we want the clamp cylinder to extend completely before the drill cylinder extends. To accomplish this we place a sequence valve just before the drill cylinder. We set the cylinder to 500 psi. This will insure that the drill will not extend before we have reached 500 psi on the clamp cylinder.

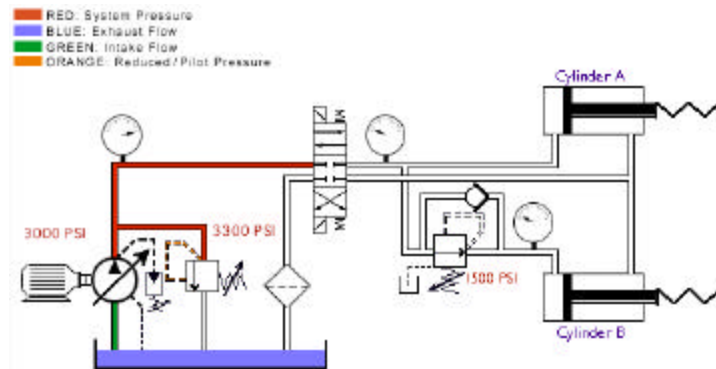

## Quiz

1. A sequence valve is a flow control valve.
  - a) True
  - b) False
2. A sequence valve is normally open.
  - a) True
  - b) False
3. The pressure downstream of a sequence valve is limited to the sequence valve's settings.
  - a) True
  - b) False

## Pressure Reducing

A pressure reducing valve is a normally open pressure control valve used to limit pressure in one or more legs of a hydraulic circuit. Reduced pressure results in a reduced force being generated. A pressure reducing valve is the only pressure control valve that is normally open. A normally open pressure control valve has primary and secondary passages connected. Pressure at the bottom of the spool is sensed from the pilot line which is connected to the secondary port. **Remember, a pressure reducing valve is normally open.**

## NOTES

---

The illustrated clamp circuit requires that clamp cylinder B apply a lesser force than clamp cylinder A. A pressure reducing valve placed just before the clamp cylinder B will allow flow to go to the cylinder until pressure reaches the setting of the valve.

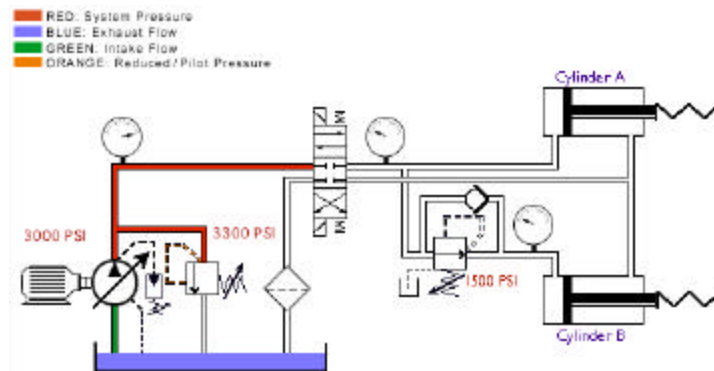

At this point, the valve begins to close off, limiting any further buildup of pressure. As fluid bleeds to the tank through the valve drain passage, pressure will begin to decay off and the valve will again open. The result is a reduced modulated pressure equal to the setting of the valve

### Quiz

1. A pressure reducing valve is the only normally open pressure control valve.
  - a) True
  - b) False
2. Pressure reducing valves are used to limit maximum system pressure.
  - a) True
  - b) False
3. Unlike other pressure control valves, the pressure reducing valve senses its pilot from the secondary port of the valve.
  - a) True
  - b) False

## NOTES

---

A **High-Low pump** system provides a high volume flow at low pressure and low volume flow at high pressure. These circuits are used to extend and retract the loads at low pressure and high flow, followed by high pressure, low volume flow to do work. Inasmuch as the power required is the product of pressure and flow, a High-Low system allows components and input motors to be kept small which increases operating efficiency by sizing the system to load requirements.

(Hydraulic hp = pressure x flow rate , 1714)

Consider a **High-Low pump** circuit that incorporates an 18 gpm pump which unloads at 1000 psi and a 10 gpm pump which relieves at 3000 psi. What is the maximum **theoretical** input fluid hp required?

- A. 8.5 hp
- B. 17.5 hp
- C. 12.5 hp
- D. 20 hp

### **Solution**

Just prior to unloading, the system will supply 28 gpm (18 gpm + 10 gpm) at 1000 psi. Based on our theoretical input horsepower formula, the required hp=16.3. With the 18 gpm pump unloading we supply only 10 gpm at 3000 psi. Again, using our formula, we calculate 17.5 hp required.

**Answer:** 17.5 hp (theoretical)

## Unloading

An unloading valve is a remotely piloted, normally closed pressure control valve that directs flow to the tank when pressure at that location reaches a predetermined level. A good example of an unloading valve application would be a High-Low system. A High-Low system may consist of two pumps; one high volume pump, the other a low volume pump. The system is designed to give a rapid approach or return on the work cylinder. The total volume of both pumps is delivered to the work cylinder until the load is contacted.

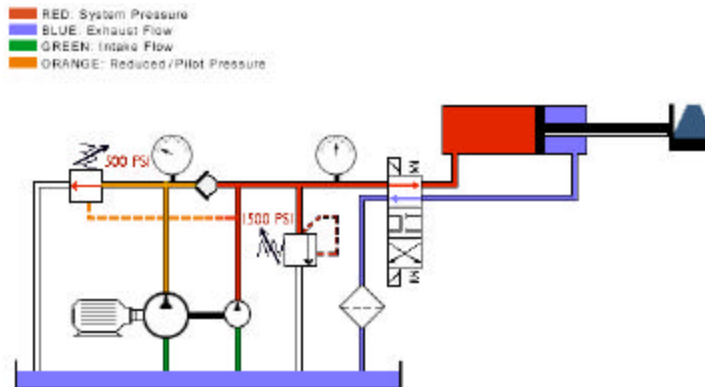

At this point the system pressure increases, causing the unloading valve to open. The flow from the large volume pump is directed back to the tank at a minimal pressure. The small volume pump continues to deliver flow for the higher pressure requirement of the work cycle.

Both pumps join again for rapid return of the cylinder. This application allows less input horsepower for speed and force requirements.

## Quiz

1. When an unloading valve opens, it directs flow directly back to the tank.
  - a) True
  - b) False
2. Since the unloading valve is remotely piloted, it can allow flow to return to the tank at minimal pressure.
  - a) True
  - b) False
3. Flow dictates when an unloading valve will open.
  - a) True
  - b) False

## NOTES

---

**Counterbalance valves** may prevent a loaded cylinder from falling. Pilot check valve circuits also hold loaded cylinders in place. Both types of circuits have unique applications. Counterbalance valves may be leak-free. For example, manufacturers commonly give the leakage rates across a counterbalance spool in drops per minute. If a cylinder must be locked in place with a valve that allows no leakage across the spool, the valve must be designed to do so.

**Counterbalance valves** may also incorporate external piloting for smoother, “non hunting” performance. When the manufacturer utilizes both internal and external pilots you have the best of both worlds. The internal pilot lowers the load with counter pressure, while the external pilot drops all back pressure when performing work.



## Counterbalance

A counterbalance valve is a normally closed pressure valve used with cylinders to counter a weight or potentially overrunning load. In this circuit, without a counterbalance valve the load would fall uncontrolled or overrun, and pump flow would not be able to keep up. To avoid the uncontrolled operation, we place a counterbalance valve just after the cylinder.

The pressure setting of the counterbalance valve is set slightly above the load-induced pressure of 1100 psi. This counters the load. As we extend the cylinder, pressure must slightly rise to drive the load down.

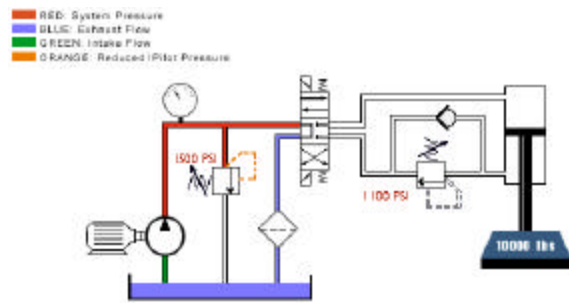

## Quiz

1. A counterbalance valve is a normally open flow control valve.
  - a) True
  - b) False
2. A counterbalance valve is used to control a cylinder with a negative or running load to move at a controlled rate.
  - a) True
  - b) False
3. The counterbalance valve should be set at a pressure slightly higher than the load-induced pressure caused by the weight on the cylinder.
  - a) True
  - b) False

## NOTES

---

A **brake circuit** utilizing a brake control valve is necessary on a rotary actuator where speed control and stopping capacity are required.

*This is also a remote piloted counterbalance valve. Brake valve usually implies that it is used with a motor circuit.*

## Brake

A brake valve is a normally closed pressure control valve with both direct and remote pilot connected simultaneously for its operation. This valve is frequently used with hydraulic motors for dynamic braking.

Because any downstream resistance will add to the load on the hydraulic motor, we pilot remotely, using working pressure to keep the valve open during running. This eliminates back pressure on the motor.

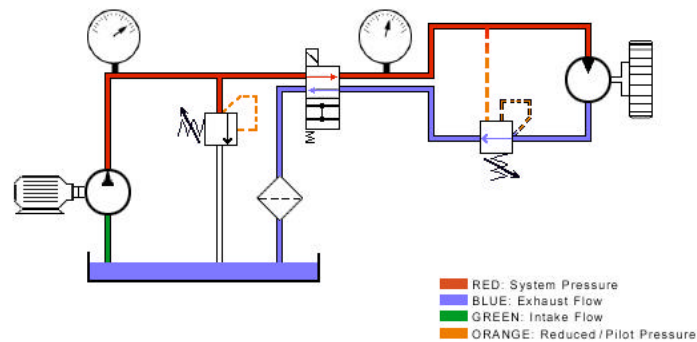

When we de-energize the directional valve, remote pilot pressure is lost, allowing the valve to close. The inertia of the load will now drive the valve open via the internal pilot, giving us dynamic braking.

## Quiz

1. The brake valve uses a remote pilot to maintain a constant back pressure on the motor.
  - a) True
  - b) False
2. The brake valve has two pilots for the purpose of allowing the installer more plumbing options.
  - a) True
  - b) False
3. When the directional control valve is centered, the brake valve allows a controlled amount of back pressure to build in the line between the motor and the brake valve to achieve dynamic braking.
  - a) True
  - b) False

## NOTES

---

## **Summary**

Brake valve: The brake valve serves two purposes. It prevents a load from over speeding the motor, and when the directional control valve is centered, it brings the motor to a stop at a controlled rate of speed.

Unloading valve: When the system pressure reaches the unloading valve setting, the valve opens diverting flow from the larger pump back to the tank at minimum pressure.

Pressure relief valve: This valve limits the maximum system pressure.

Sequence valve: If properly adjusted, the sequence valve assures that the cylinder will fully extend before the motor starts.

Counterbalance valve: Counterbalance valves are used to aid a cylinder in lowering a load at a controlled rate.

Pressure reducing valve: The reducing valve will limit the pressure to the motor, thus limiting the output torque of the motor.

## NOTES

---

*Directional control valves y also be of the “poppet” design. They have seating elements in the form of balls, poppets or plates. The advantage of the poppet design are zero leakage and no sticking under high pressure.*

# DIRECTIONAL CONTROL VALVE

## Overview

The directional control valve is the component that starts, stops, and changes the direction of the fluid flowing through a hydraulic system. In addition to this, the directional control valve actually designates the type of hydraulic system design, either open or closed. The exercises in this section will give you a hands-on opportunity to see how these valves actually operate and the importance that they play in proper system function.

Directional control valves are used to start, stop, and change the direction of flow in a hydraulic circuit. Although they may be designed as rotary or poppet style, the spool type directional control is the most common. This design consists of a body with internal passages that are connected or sealed by a sliding spool along the lands of the valve. Directional spool valves are sealed along the clearance between the moving spool, land and the housing. The degree of sealing depends on the clearance, the viscosity of the fluid, and the pressure. Because of this slight leakage, spool type directional valves can not alone hydraulically lock the actuator.

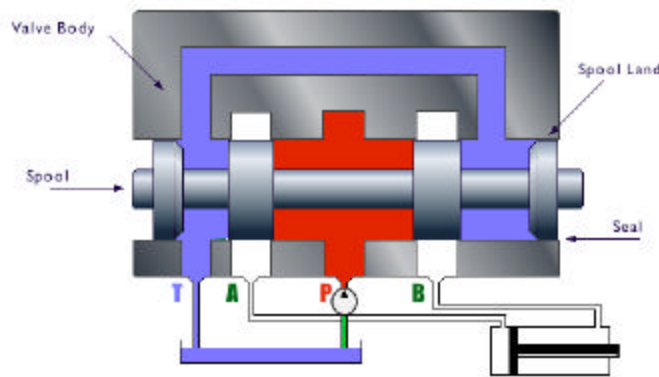

Directional control valves are primarily designated by their number of possible positions, port connections or ways, and how they are actuated or energized. For example, the number of porting connections are designated as ways or possible flow paths. A four-way valve would have four ports: P, T, A, and B. A three-position valve is indicated by three connected boxes. There are many ways of actuating or shifting the valve. They are: push button, hand lever, foot pedal, mechanical, hydraulic pilot, air pilot, solenoid, and spring.



## NOTES

---



Directional control valves may also be designated as normally opened or normally closed. These designations would accompany two-position valves such as the following: spring offset, solenoid operated, two-way valve normally closed; spring offset, solenoid operated, two-way valve normally open; spring offset, solenoid operated, three-way valve normally closed; spring offset, solenoid operated three-way valve normally open.

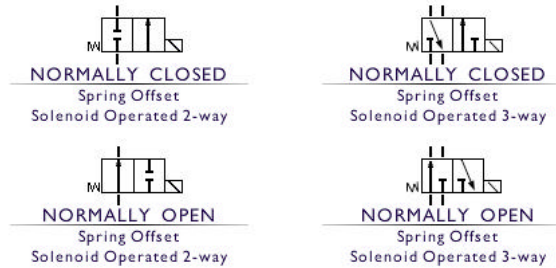

The spool type directional control valves in industrial applications are sub-plate or manifold mounted. The porting pattern is industry standard and designed by valve size. Directional control valve sizing is according to flow capacity which is critical to the proper function of

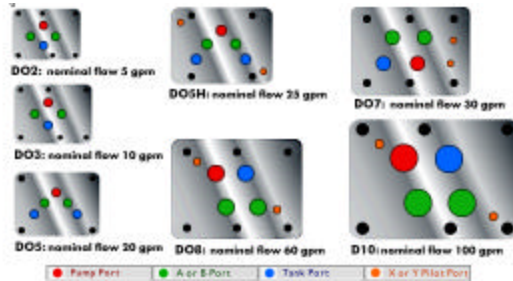

the valve. Flow capacity of a valve is determined by the port sizes and the pressure drop across the valve. This mounting pattern and size is designed as a D02 nominal flow 5 gpm, D03 nominal flow 10 gpm, D05 nominal flow 20 gpm, D05H nominal flow 25 gpm, D07 nominal flow 30 gpm, D08 nominal flow 60 gpm, D10 nominal flow 100 gpm.

## NOTES

---

*Single and double solenoid control valves are available with DC solenoids or AC 50/60 Hz 120 volt solenoids.*

*Most solenoid actuated valves are equipped with manual overrides, allowing the spool to be shifted by hand. This is accomplished by depressing the pin located in the end of the push pin tube located at each end of the valve.*

*Piloted operated directional control valves must have a provision to drain the pilot oil at the opposite end of the spool in order for the valve spool to shift. Blocking the drain or "Y" port of an externally drained valve will prevent the spool from shifting.*

## Direct Acting

A direct acting directional control valve may be either manual or solenoid actuated. Direct acting indicates that some method of force is applied directly to the spool, causing the spool to shift. In our illustration, energizing the solenoid or coil creates an electromagnetic force which wants to pull the armature into the magnetic field. As this occurs, the connected push pin moves the spool in the same direction while compressing the return spring. As the spool valve shifts, port P opens to port A, and port B opens to port T or tank. This allows the cylinder to extend. When the coil is de-energized, the return springs move the spool back to its center position.

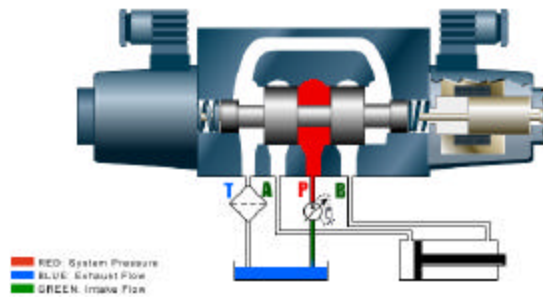

## Pilot Operated

For control of systems requiring high flows, usually over 35 gpm, pilot operated directional control valves must be used due to the higher force required to shift the spool. The top valve, called the pilot valve, is used to hydraulically shift the bottom valve, or the main valve. To accomplish this, oil is directed from either an internal or an external source to the pilot valve. When we energize the pilot valve, oil is directed to one side of the main spool. This will shift the spool, opening our pressure port to the work port and directing return fluid back to the tank. It is often required to externally pilot or send fluid to the pilot valve from an external source.

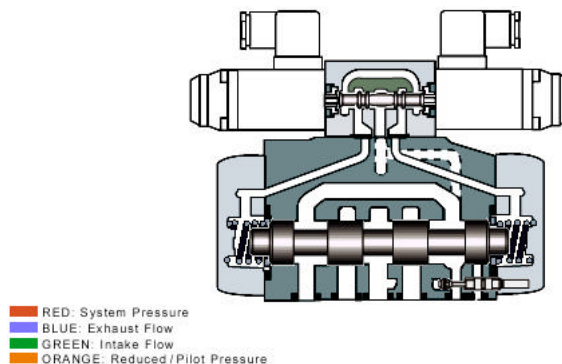

## NOTES

---

*All "spool" type directional control valves have some leakage by the spool. This slight leakage may cause a cylinder to extend under pressure or drift down under load. The application may require the use of a pilot operated check valve in conjunction with a float center.*

The advantages to external piloting are constant pressure supply regardless of other influences in the main system, and the source may be filtered separately to prevent silting of the pilot valve. In addition to externally piloting, we may also externally or internally drain the valve. If the pilot valve is internally drained, oil flows directly into the tank chamber of the main valve. Pressure or flow surges occurring in the tank port when operating the main control spool may affect the unloaded side of the main spool, as well as the pilot valve. To avoid this, we may externally drain the pilot valve by feeding pilot oil flow back to the tank. Pilot operated directional control valves may be field changed from internal to external pilot and drain.

### Open vs. Closed Center

We can categorize most hydraulic circuits into two basic types: open center or closed center. The directional control valve actually designates the type of circuit. Open center circuits are defined as circuits which route pump flow back to the reservoir through the directional control valve during neutral or dwell time. This type of circuit typically uses a fixed volume pump, such as a gear pump. If flow were to be blocked in neutral or when the directional control valve is centered, it would force flow over the relief valve. This could possibly create an excessive amount of heat and would be an incorrect design. A closed center circuit blocks pump flow at the directional control valve, in neutral or when centered. We must utilize a pressure compensated pump, such as a piston pump, which will de-stroke, or an unloading circuit used with a fixed volume pump.

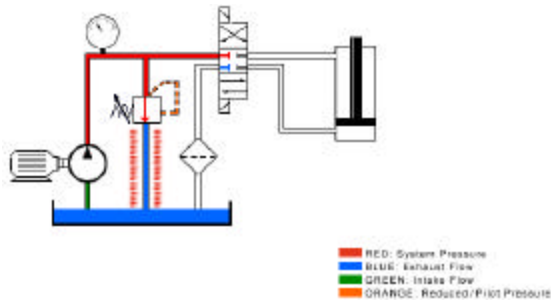

A three-position directional control valve incorporates a neutral or center position which designates the circuit as open or closed, depending on the interconnection of the P and T ports, and designates the type of work application depending on the configuration of the A and B ports. The four most common types of three-position valves are: open type, closed type, flow type, and tandem type.

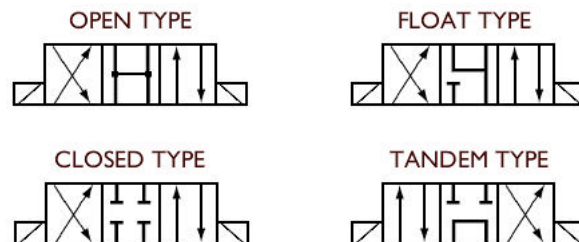

## NOTES

---

This open type configuration connects P, T, A, and B together, giving us an open center and work force that drain to the tank. This configuration is often used in motor circuits to allow freewheeling in neutral.

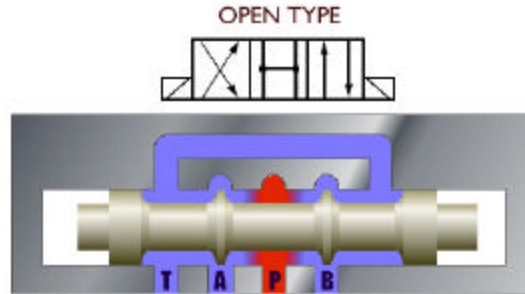

This closed type configuration blocks P, T, A, and B in neutral, giving us a closed center. This center type is common in parallel circuits where we want to stop and hold a load in mid-cycle.

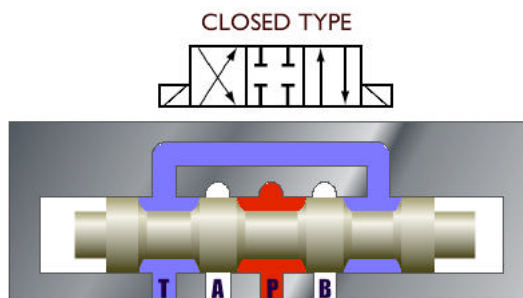

This float type configuration blocks P while interconnecting A and B ports to T. Because P is blocked, the circuit becomes closed center. This center type is commonly used in parallel circuits where we are freewheeling a hydraulic motor in neutral.

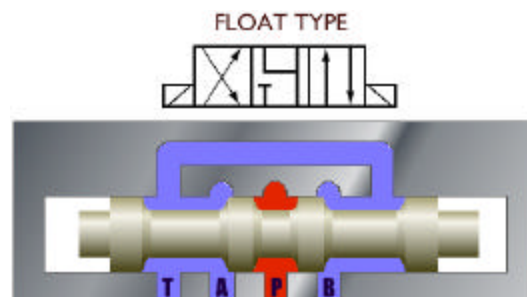

## NOTES

---



This tandem type configuration connects P to T while blocking work ports A and B. With P and T connected, we have an open center circuit. This center type is used in connection with a fixed displacement pump. Because A and B are blocked, the load can be held in neutral.

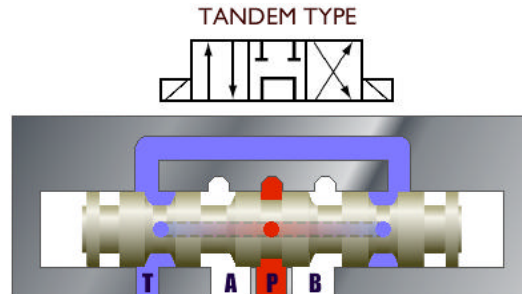

When specifying a directional control valve type, one must consider the type of circuit required and the work application.

### Quiz

1. A closed center system maintains constant flow, but no pressure when the directional control valve is centered.
  - a) True
  - b) False
2. The type of pump (fixed vs. pressure compensated) designates whether we have an open or closed center system.
  - a) True
  - b) False
3. In an open center system, flow passes through the valve center and back to tank at low pressure when the valve is centered.
  - a) True
  - b) False

## NOTES

---

*Flow control valves, when metering, add resistance to the circuit, which adds heat and load to the system. Fixed displacement pump circuits must force excess flow over the relief valve to meter. This creates much more heat than variable displacement pumps, which partially de-stroke the pump from the valve closure, rather than force excess flow over a relief valve.*

# FLOW CONTROL VALVES

## Introduction

Flow control valves are used to regulate the volume of oil supplied to different areas of hydraulic systems. In this section you will be given an overview of the two types of flow control valves, as well as their application and location in a hydraulic system. Because a proper placement of these devices is critical to optimum system performance, a section has been provided to help you learn why and where flow control devices should be used.

## Overview

The function of the flow control valve is to reduce the rate of flow in its leg of the circuit. Flow reduction will result in speed reduction at the actuator. A flow control valve builds added resistance to the circuit, increasing pressure, resulting in a partial bypassing of fluid over the relief valve or a de-stroking pressure of a compensated pump. This reduces flow downstream of the flow control valve.

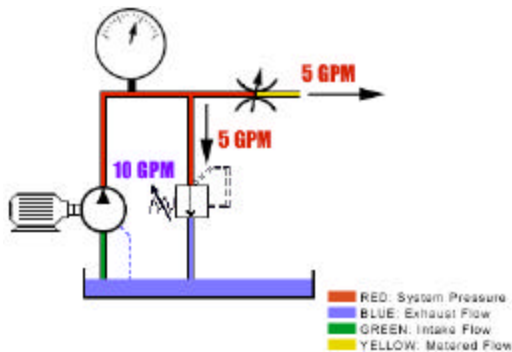
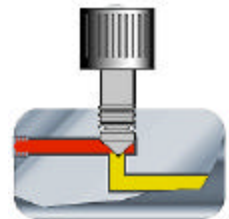

In a fixed volume pump, to reduce flow to the actuator, we must bypass a portion of the fluid over the relief valve. As we close the needle valve, pressure increases upstream. As we approach 1500 psi the relief valve begins to open, bypassing a portion of fluid to the reservoir.

With flow control used in a pressure compensated pump, we do not push fluid over the relief valve. As we approach the compensator setting of 1500 psi, the pump will begin the de-stroke, reducing outward flow.

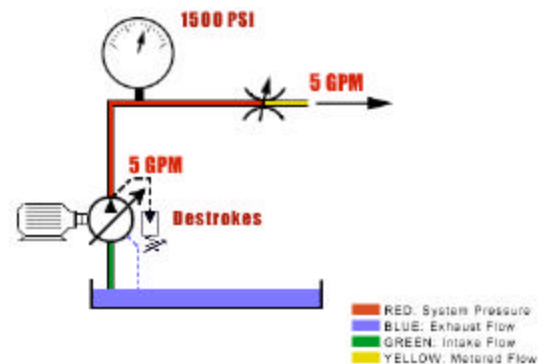

## NOTES

---

*A pressure compensated flow control valve may also be temperature compensated as well. Temperature compensation allows for change in fluid viscosity due to temperature changes in the hydraulic oil.*

Flow control valves may be fixed or non-adjustable or adjustable. In addition, they may also be classified as throttling only or pressure compensated.

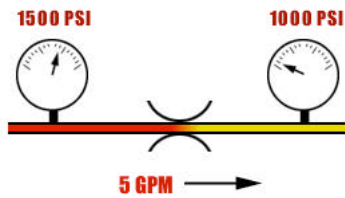
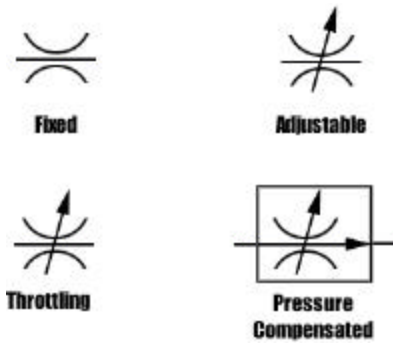

The amount of flow through an orifice will remain constant as long as the pressure differential across the orifice does not change. When the pressure differential changes, the flow changes. Changing load or upstream pressure will change the pressure drop across the valve.

### Throttling vs. Pressure Compensating

#### Needle Valves

Needle valves may be designated as non-compensated flow control or throttling valves. They are good metering devices as long as the pressure differential across the valve remains constant.

A pressure compensated flow control valve is designed to make allowances for pressure changes ahead or after the orifice. The pressure compensated flow control valve symbol adds a pressure arrow to the orifice. Notice that with a pressure compensated flow control valve, the speed of the cylinder does not change with the change in load.

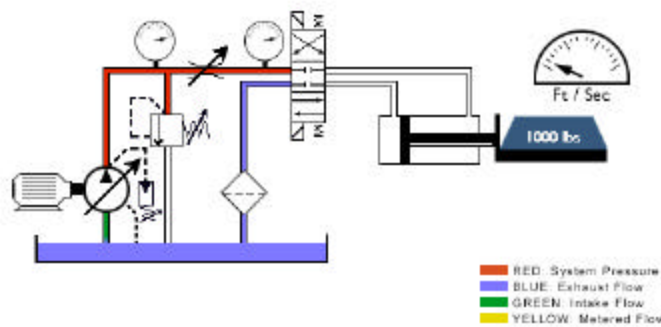

## NOTES

---

## Quiz

1. Flow controls are always adjustable.
  - a) True
  - b) False
2. Flow controls are often used to control the speed of an actuator.
  - a) True
  - b) False
3. Flow through a throttling valve will vary if the differential pressure across the valve varies.
  - a) True
  - b) False
4. A pressure compensated flow control valve maintains a constant flow by maintaining a constant pressure upstream from the valve.
  - a) True
  - b) False

## Meter-In Meter-Out

Meter-in is the method of placing a flow control valve in such a way that fluid is restricted to the actuator. In this circuit, without a flow control valve the cylinder extends and retracts at an unrestricted rate. When we place a flow control valve into the circuit this flow control valve will restrict flow to the cylinder, slowing the extend rate of the cylinder. The check valve allows return flow to bypass the flow control when direction of flow is reversed.

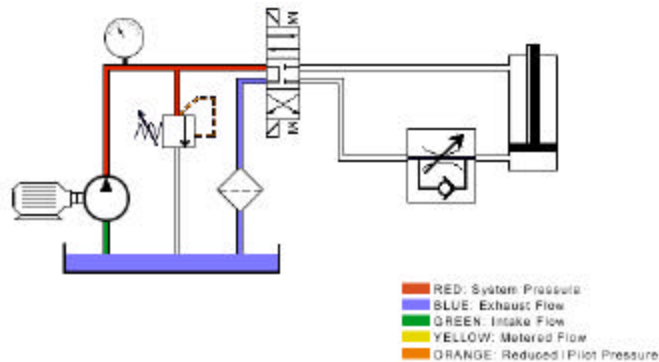

## NOTES

---



When we move the flow control to the other line, the cylinder extends at an unrestricted rate. We can restrict the flow to the cylinder so that it will retract at a reduced rate.

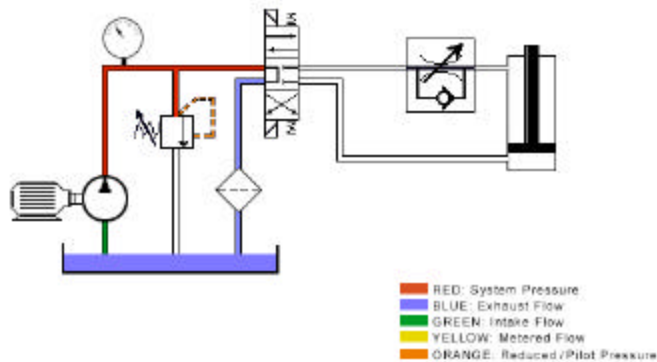

The advantage to meter-in is that it is very accurate with a positive load. However, when the load goes over center, the load becomes negative or overrunning. The load is no longer being controlled by the cylinder. As the load overruns, it causes the cylinder to cavitate.

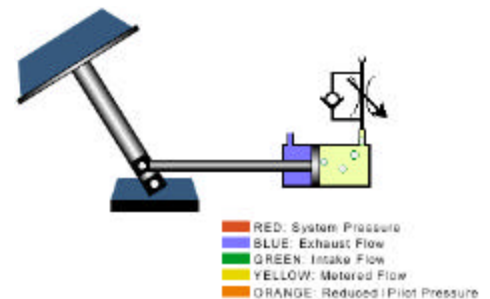

Although meter-in is usually the best placement for controlling a constant speed, because it also dampens flow and pressure transients, it may be required in some applications to meter-out. To meter-out we simply change the direction that the flow is allowed to pass through the reverse check. This will cause the fluid to be metered as it leaves the actuator, which is opposite of meter-in.

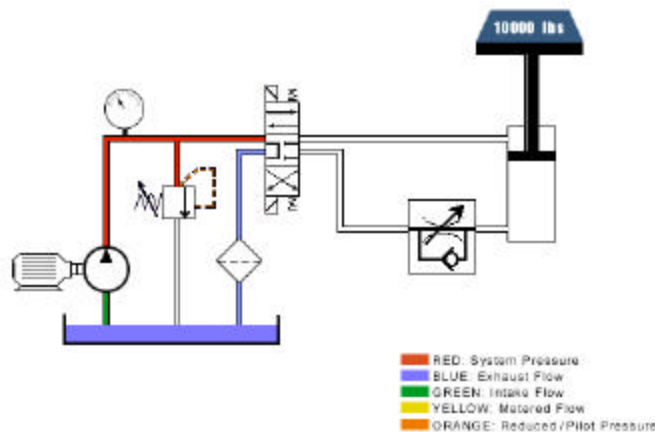

## NOTES

---

An advantage of meter-out is that it will prevent a cylinder from overrunning and consequently cavitating. A disadvantage of meter-out can be pressure intensification. This can occur with a substantial differential area ratio between the rod ends and piston. When we meter-out on the rod side of the cylinder without a load, the pressure is intensified on the rod side. This may damage the rod seals. Meter-in or meter-out has advantages and disadvantages. The application must determine the type of flow control valve placement.

RED: System Pressure  
BLUE: Exhaust Flow  
GREEN: Intake Flow  
YELLOW: Metered Flow  
ORANGE: Reduced and/or Pilot Pressure  
PURPLE: Potential Intensified Pressure

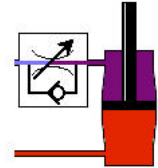

### Quiz

1. Meter-in should only be used with a positive load.
  - a) True
  - b) False
2. When metering-in one must always use a pressure compensated flow control.
  - a) True
  - b) False
3. Meter-in refers to controlling the flow going to the actuator.
  - a) True
  - b) False

## NOTES

---

*Ingression is defined as the rate at which external contaminants enter the system from the cylinder rods, air breathers, shaft seals and other possible points of entry.*

# FLUID CONDITIONING

## Introduction

Fluid conditioning is critical in maintaining proper operation of a hydraulic system. In this section, you will learn about different types of filters, their location, and how they keep hydraulic fluid clean. You will also learn about the importance of regulating the temperature of hydraulic fluid with devices like heat exchangers. For example, fluid that is too hot or too cold can have a negative impact on system performance.

## **Filtration**

### Overview

Cleanliness of hydraulic fluid has become critical in the design and operation of fluid power components. With pumps and valves designed to closer tolerances and finer finishes, fluid systems operate at ever increasing pressures and efficiencies. These components will perform as designed as long as the fluid is clean. Oil cleanliness results in increased system reliability and reduced maintenance.

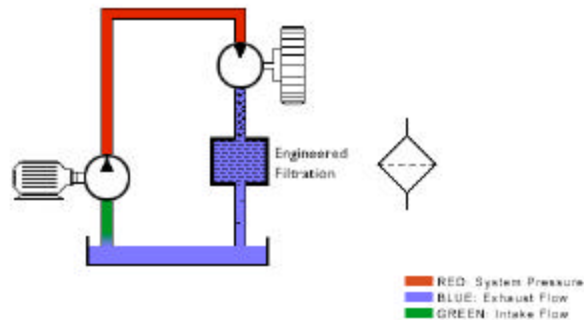

As particles are induced or ingressed into a hydraulic system, they are often ground into thousands of fine particles. These tiny particles are tightly packed between valve spools and their bores, causing the valve to stick. This is known as silting.

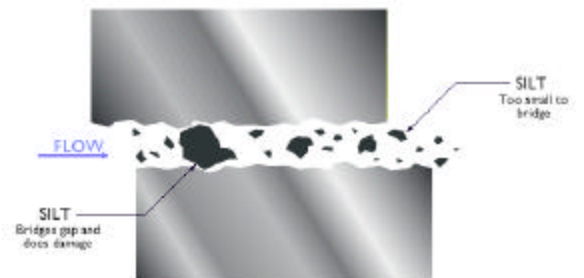

To prevent silting, early component wear, and eventual system failure, engineered filtration is required. Engineered filtration includes: understanding required micron rating, application of the beta ratio, maintaining proper ISO code cleanliness levels, filter location specific to the system design and environment.

## NOTES

---

To convert **beta ratio** into percentages, take the reciprocal of the beta ratio ( $1 \div \mathbf{b}$ ) and subtract it from 100%.

**Formula:**  $100\% - (1 \div \mathbf{b}) = \% \text{ efficiency.}$

## Terminology

### Micron (mm)

Micron ( $\mu\text{m}$ ) is the designation used to describe particle sizes or clearances in hydraulic components. A micron is equal to 39 millionths of an inch. To put this into perspective the smallest dot that can be seen by the naked eye is  $40\ \mu\text{m}$ .

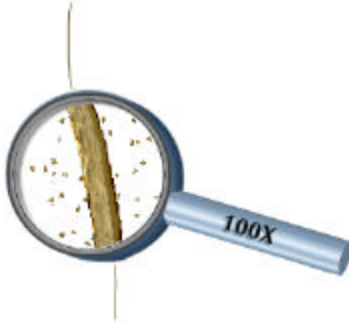

Consider the following illustration. If we looked at a human hair magnified 100 times the particles you see next to the hair are about  $10\ \mu\text{m}$ . Industrial hydraulic systems usually filter in the  $10\ \mu\text{m}$  range. This means that filters are filtering particles that can not be seen by the naked eye.

### Beta ratio

Filtration devices are used to filter particles out of the system's fluid. A filter's efficiency is rated with a beta ratio. The beta ratio is the number of particles upstream from the filter that are larger than the filter's micron rating divided by the number of particles downstream larger than the filter's micron rating.

In this example there are 200 particles upstream which are larger than  $3\ \mu\text{m}$ . These flow up to and through the filters.

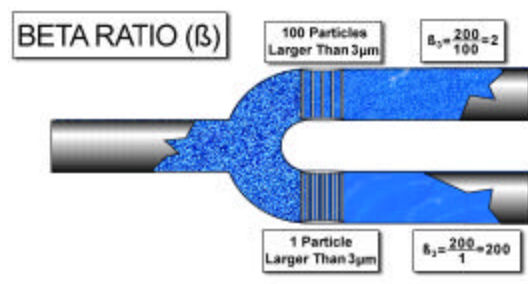

A filter that allows more particles through or in other words, one that is less efficient, has a low beta ratio. You can see that the filter at the top allowed 100 particles through. The filter on the bottom allowed only 1 particle through.

If we apply these numbers to the beta ratio formula, we can see that the filter at the top has a lower or less efficient beta ratio and the filter at the bottom has a higher or more efficient beta ratio.

## NOTES

---



## ISO Code

To specify the cleanliness level of a given volume of fluid we refer to what is known as an ISO code, or ISO solid contamination code. This code, which applies to all types of fluid, provides a universal expression of relative cleanliness between suppliers and users of hydraulic fluid.

Based on 1 milliliter of fluid, a particle count is analyzed using specific sizes of particles, 4  $\mu\text{m}$ , 6  $\mu\text{m}$ , and 14  $\mu\text{m}$ . These three sizes were selected because it gives an accurate assessment of the amount of silt from 4  $\mu\text{m}$  particles and 6  $\mu\text{m}$  particles, while the number of particles above 14  $\mu\text{m}$  reflects the amount of wear type particles in the fluid.

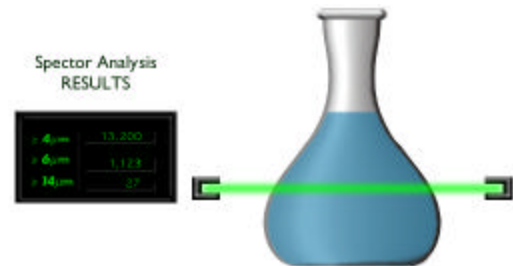

To interpret the meaning of these results a graph like the one shown would have been consulted. In this example, a rating of 22/18/13 indicates the following: The first number 22 indicates the number of particles greater than or equal to 4  $\mu\text{m}$  in size is more than 20,000 and less than or equal to 40,000, per milliliter. The second number 18 indicates the number of particles greater than or equal to 6  $\mu\text{m}$  in size is more than 1,300 and less than or equal to 2,500, per milliliter. The third number 13 indicates the number of particles greater than or equal to 14  $\mu\text{m}$  in size is more than 40 and less than or equal to 80, per milliliter.

Spector Analysis RESULTS

Number of particles per 1.0 ml					
ISO 4406 Code Table					
Scale No.	More than	& up to	Scale No.	More than	& up to
0	0.00	0.01	15	140	320
1	0.01	0.02	16	320	640
2	0.02	0.04	17	640	1.3k
3	0.04	0.08	18	1.3k	2.5k
4	0.08	0.16	19	2.5k	5k
5	0.16	0.32	20	5k	10k
6	0.32	0.64	21	10k	20k
7	0.64	1.3	22	20k	40k
8	1.3	2.5	23	40k	80k
9	2.5	5	24	80k	160k
10	5	10	25	160k	320k
11	10	20	26	320k	640k
12	20	40	27	640k	1.3M
13	40	80	28	1.3M	2.5M
14	80	160	>28	2.5M	

This ISO code is meaningful only if we can relate it to the required cleanliness level of our hydraulic system. This is usually based on a manufacturer's requirement for cleanliness levels in which a component may operate. For example: Most servo valves require a ISO code of 15/13/12 or better, while gear pumps may operate adequately in fluids with 18/16/15 ISO.

## NOTES

---

## Placement

Filter placement is critical for maintaining acceptable fluid cleanliness levels, adequate component protection, and reducing machine downtime. Filter breathers are critical in prevention of airborne particulate ingress. As the system operates, the fluid level in the reservoir changes. This draws in outside air and with it, airborne particulates. The breather filters the air entering the reservoir.

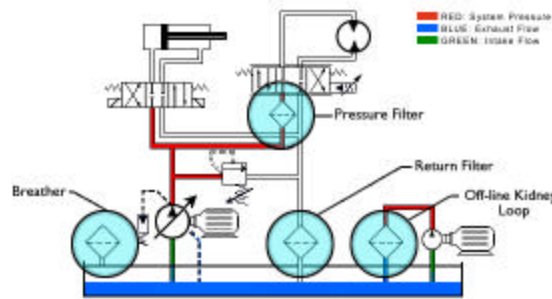

Pressure filters are often required to protect the component immediately downstream of the filter, such as a sensitive servo valve, from accelerated wear, silting, or sticking. Pressure filters must be able to withstand the operating pressure of the system as well as any pump pulsations. Return filters best provide for maintaining total system cleanliness, depending on their  $\mu\text{m}$  rating (beta ratio). They can trap very small particles before they return to the reservoir. They must be sized to handle the full return flow from the system. A kidney loop or off-line filtration is often required when fluid circulation through a return filter is minimal. Being independent of the main hydraulic system, off-line filters can be placed where they are most convenient to service or change. Off-line filtration normally runs continuously.

## QUIZ

1. The beta ratio of 75
  - a) is less efficient than beta 100.
  - b) is more efficient than beta 100.
  - c) indicates the micron size.
  - d) none of the above.
2. In determining a filter's beta ratio, the micron rating
  - a) is critical.
  - b) does not apply to the efficiency.
  - c) is smaller than the particles being filtered.
  - d) is larger than the particles being filtered.
3. Filter breathers are critical in prevention of airborne particulate ingress.
  - a) True
  - b) False

## NOTES

---

## HEAT EXCHANGERS

### Types

Temperature control is critical in hydraulic systems. Even with the best circuit design, there are always power losses in converting mechanical energy into fluid power. Heat is generated whenever fluid flows from high to low pressure without producing mechanical work. Heat exchangers may be required when operating temperatures are critical or when the system cannot dissipate all the heat that is generated.

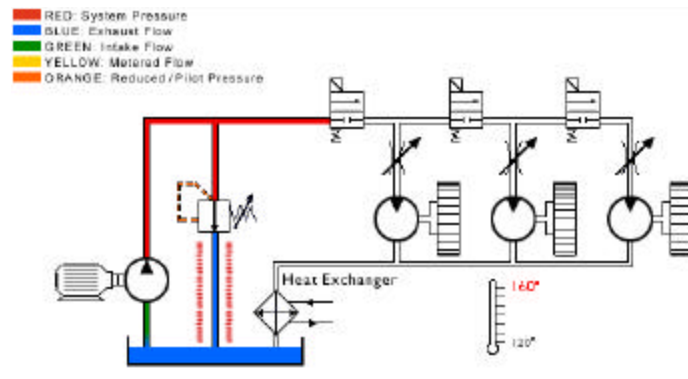

There are two basic types of heat exchangers. Each is based on a different cooling medium: water cooled heat exchangers and air cooled heat exchangers. If cooling water is available, a **shell and tube heat exchanger** may be preferred. Cooling water is circulated through a bundle of bronze tubes from one end cap to the other. Hydraulic fluid is circulated through the unit and around the tubes containing the water. The heat is removed from the hydraulic fluid by the water. There are advantages to this type of cooler. They are the least expensive, they are very compact, they do not make noise, they provide consistent heat removal year round, and they are good in dirty environments. The disadvantages are: water costs can be expensive, with rupture oil and water may mix, and usually require regular maintenance from mineral buildup.



**Air cooled heat exchangers** consist of a steel radiator core through which oil flows while a strong blast of air passes across the core. In industrial applications the air is pushed by an electric motor driven fan. The advantages of this type of air cooled heat exchanger are: they eliminate problems associated with cooling water, they have low installed costs, and the dissipated heat can be reclaimed. The disadvantages are: there is a higher installation cost, noise levels range from 60 to 90 decibels, and they are larger in size than comparable water cooled equipment.



## NOTES

*Reservoirs may be classified as vented or pressurized. Vented reservoirs are open to the atmosphere. Pressurized reservoirs offer several advantages over vented: contaminants and condensation are reduced, and pressurized reservoirs help force fluid into the pump inlet.*

## RESERVOIRS

In addition to holding the system's fluid supply, the reservoir serves several other important functions. It cools the hydraulic fluid. This is accomplished by dissipating excess heat through its walls. It conditions the fluid. As oil waits to leave the reservoir solid contaminants settle while air rises and escapes. The reservoir may provide mounting support for the pump or other components.

A well designed hydraulic system always includes a properly designed reservoir. An industrial reservoir should include the following components: a baffle plate to prevent returning fluid from entering the pump inlet, a clean out cover for maintenance access, a filter breather assembly to allow air exchange, a filler opening well protected from contaminant ingress, a level indicator allowing upper and lower levels of fluid to be monitored, and adequate connections and fittings for suction lines, return lines, and drain lines.

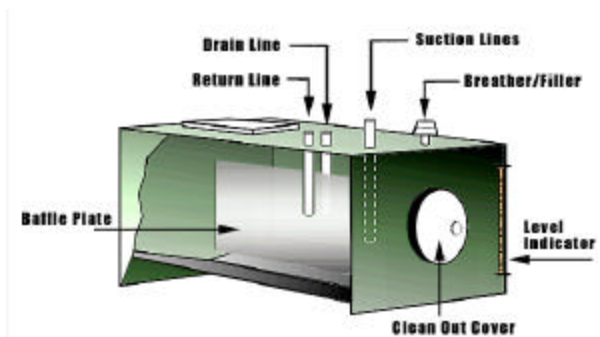

It is often stated that the hydraulic fluid is the heart of the system or the most important component. The reservoir serves a critical role in maintaining the efficiency of fluid transfer and conditioning.

## Quiz

1. Reservoirs help to condition hydraulic fluid, as well as storing the fluid.
  - a) True
  - b) False
2. Hydraulic fluid returning to the reservoir may contain entrained air and solid contaminants.
  - a) True
  - b) False
3. All fluid conductor lines entering the reservoir terminate below the fluid level.
  - a) True
  - b) False

## NOTES

---

*Pilot operated check valves may be pilot to open or pilot to close. This is determined by the application.*



# CHECK VALVES

## Introduction

Check valves are a simple but important part of a hydraulic system. Simply stated, these valves are used to maintain the direction that fluid flows through a system. And since check valves are zero leakage devices we can use them to lock hydraulic fluid from the cylinders. This section has been designed to help you understand how the different valves function and the strategy of where they are used in the system.

## In-line

In-line check valves are classified as directional control valves because they dictate the direction flow can travel in a portion of the circuit. Because of their sealing capability many designs are considered to have zero leakage. The simplest check valve allows free flow in one direction and blocks flow from the opposite direction. This style of check valve is used when flow needs to bypass a pressure valve during return flow, as a bypass around a filter when a filter becomes clogged, or to keep flow from entering a portion of a circuit at an undesirable time.

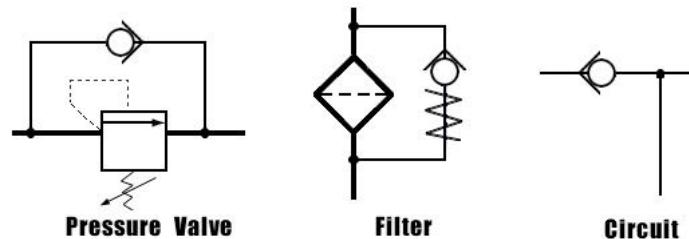

## Pilot Operated

Because of slight spool leakage on standard directional control valves, we must add a check valve to the circuit if we need to hydraulically lock a cylinder. This type of check valve is referred to as a pilot operated check valve.

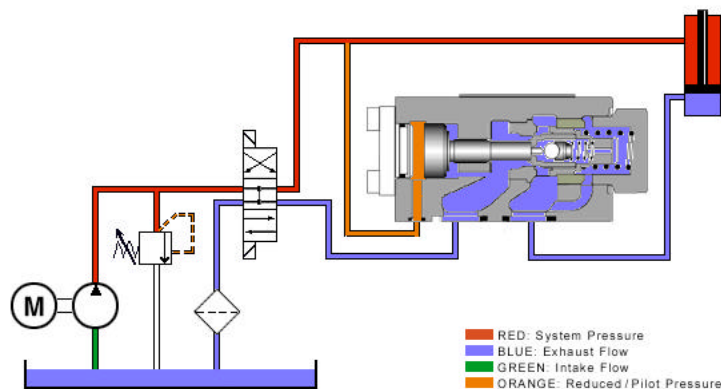

## NOTES

---

Unlike a simple check valve, reverse flow is required through the valve to extend or retract the cylinder. This is accomplished by allowing pilot pressure to act on a pilot piston, thus opening the check valve and retracting the cylinder.

To extend the cylinder, the check valve allows fluid to flow freely in one direction and blocks flow in the opposite direction.

.

### **Quiz**

1. Check valves are classified as
  - a) pressure control valves.
  - b) flow control valves.
  - c) directional control valves.
  - d) bypass valves.
  
2. Pilot operated check valves use an external pilot to allow reverse flow to pass through the valve.
  - a) True
  - b) False
  
3. A pilot operated check valve with a pilot ratio of 10:1 would open with 200 psi pilot pressure even if there was 2000 psi back pressure on the valve.
  - a) True
  - b) False
  
4. Check valves are considered to have
  - a) much leakage.
  - b) zero leakage.
  - c) little leakage.
  - d) moderate leakage.

## NOTES

---

*Safety is an important consideration in working with accumulators. Caution must be taken not to overcharge the accumulator.*

***Accumulator circuits** should be equipped with a safety unloading valve. This valve allows the accumulators to be isolated and discharged to the tank prior to system maintenance.*

## ACCESSORY COMPONENTS

### Introduction

In this section you will be given an overview of several accessory components that are used in most hydraulic systems. You'll learn about accumulators, pressure switches, gauges, flow meters, and manifolds. These components are vital to proper system operation, and understanding how they are used in a system is an important part of this basic hydraulic course.

### Accumulators

Accumulators are devices that store energy in the form of fluid under pressure. Because of their ability to store excess energy and release it when needed, accumulators are useful tools for improving hydraulic efficiency. Industrial hydraulic accumulators are typically classified as hydropneumatic. This type of accumulator applies a force to a liquid by using compressed gas.



The two most common types of hydropneumatic accumulators are the bladder type accumulator and the piston accumulator. The name of each type indicates the device separating gas from liquid.

A hydropneumatic accumulator has a fluid compartment and a gas compartment, with a gas type element such as a bladder separating the two. The bladder is charged through a gas valve at the top of the accumulator, while a poppet valve at the bottom prevents the bladder from extruding into the pressure line. The poppet valve is sized so that the maximum volume metric flow cannot be exceeded.

To operate, the bladder is pre-charged with nitrogen to a pressure specified by the manufacturer according to the operating conditions. When the system pressure exceeds the gas pre-charged pressure, the poppet valve opens and hydraulic fluid enters the accumulator.

The changing gas volume in the bladder determines the useable volume or useful fluid capacity.

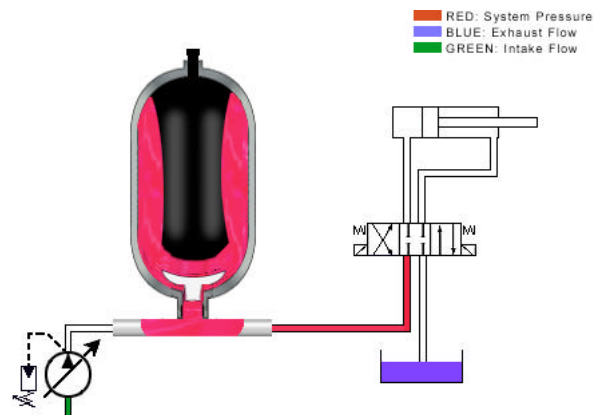

Accumulators store energy that can be used during power failure or when additional energy is needed. In certain situations additional flow may be needed. An accumulator can be used to supplement the flow rate of a pump.

## NOTES

---

***Bourdon tube*** pressure gauges are not accurate in the center half of the scale.

*Even with the gauge properly sized, shock loading or pressure spikes will damage the gear mechanism. Dampening devices help prevent this from happening.*

## **Pressure Switches**

There are two types of pressure switches: the bourbon tube switch and the piston switch, shown here. This pressure switch consists of a micro switch, a spring, a mechanical stop, a push rod, and a piston actuator. External lights are often used to indicate that the switch has been activated.

When pressure builds in the system, it enters the device, applying force to the piston actuator. This energy is transferred to the mechanical stop, compressing the spring, driving the push rod up until it activates the micro switch. Pressure switches are used to open or close an electrical circuit when a predetermined pressure has been reached.

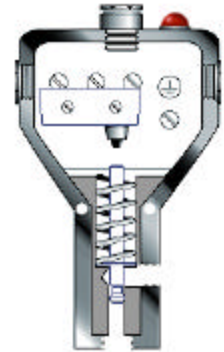

## **Pressure Gauges**



Bourbon tube pressure gauges measure the pressure in a system and display it on a calibrated dial. The units of calibration are displayed in psi, bar, and psia.

The bourbon tube is a coiled metal tube. It is connected to system pressure. Any increase in pressure within the system causes the tube to straighten out.

The end of the tube is connected to a mechanical linkage which turns a gear. This gear in turn meshes with a gear, driving the pointer needle. Watch now as the tube is pressurized, causing the needle to turn and give the new system pressure.

## NOTES

---



## Flow meters

The purpose of a flow meter is to measure flow. It is usually not bi-directional and acts as a check valve blocking flow in the reverse direction. The main components consist of: a metering cone, a magnetic piston which is held in the no-flow position by a tempered spring.

Fluid first enters the device, flowing around the metering cone, putting pressure on the magnetic piston and spring. As flow increases in the system, the magnetic piston begins to compress the spring, indicating the flow rate on the graduated scale.

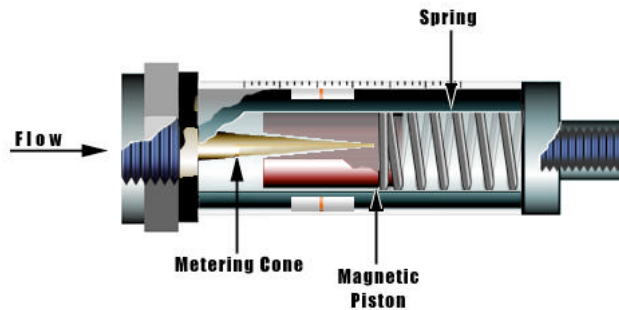

## Manifolds

As the number of connections in a hydraulic system increase, so does the possibility of leaky fittings. Hydraulic manifolds drastically reduce the number of external connections required.

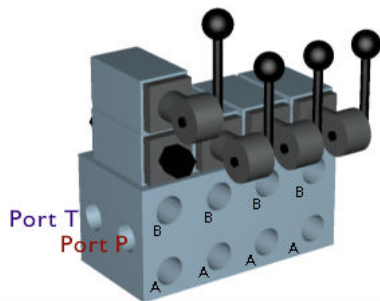

Manifolds used for modular valve stacking incorporate a common pressure and return port. With individual A and B work ports for each valve station, at each station additional control valving may be added by sandwiching or stacking the valves vertically. This is accomplished without any external connections. Manifolds are specified according to system pressure, total flow, number of work stations, valve size or pattern.

## NOTES

---

## Quiz

1. A flow meter controls the amount of flow in a circuit.
  - a) True
  - b) False
  
2. A pressure gauge measures pressure in a system and displays it on a calibrated dial.
  - a) True
  - b) False
  
3. Pressure switches are used to open or close an electrical circuit when a pre-determined pressure has been reached.
  - a) True
  - b) False
  
4. Manifolds reduce the number of connections, but increase the number of potential leak points.
  - a) True
  - b) False
  
5. Two common applications for accumulators are to store energy in a hydraulic circuit and to supplement pump flow.
  - a) True
  - b) False

## NOTES

---

*Hoses should not be installed with a twist. A slight twist in the hose can significantly reduce hose life. Twisting a hose 10° could shorten its service by as much as 90%.*

*The bending radius of a hose is the curvature of a hose from a straight line beginning at the radius of the bend. The bending radius of a hose is measured to the external cove of the hose on the inside turn.*

*The minimum bending radius of a hose is determined by the manufacturer and typically illustrated by charts.*

*The bending radius increases as the diameter of the hose increases. It must also increase with an increase in pressure.*

*Hose life is greatly reduced with system temperature increases.*

## FLUID CONDUCTORS

### Introduction

Fluid conductors are those parts of the system that are used to carry fluid to all of the various components in the hydraulic circuit. These types of conductors include: hydraulic hose, steel tubing, and steel pipe. This section will help you understand the benefits of these different conductors and where they are best used in a hydraulic system.

### Overview

Transmitting power from one location to another is a key element in system design and performance. We define this as fluid conducting. Fluid conductors describe the different types of conducting lines that carry hydraulic fluid between components. The three principle types of plumbing materials used in hydraulic systems are steel pipes, steel tubing, and flexible hose. A safety factor of 4 to 1 is recommended on the pressure rating of the plumbing material. To determine the working pressure of the conductor, we must take the rated burst pressure and divide by the safety factor of 4.

### Hose

Hydraulic hoses are used in applications where lines must flex or bend. In considering the use of hoses, one must first look at system pressure, pressure pulses, velocity, fluid compatibility, and environmental conditions. Hose construction has been standardized by the Society of Automotive Engineers under SAE J5-17. This is known as the R series. As an example, 100R2 or 100R4. This designation describes the cover, construction, pressure rating and application.



Hoses are usually pressure rated with a safety factor of 4 to 1. Different types and amounts of reinforcement give the hose specific pressure ratings. The reinforcement may be a natural or synthetic fiber or metal wire. The reinforcement may be braided or spiral bond. Required hose size depends on the volume and velocity of the fluid flow. Unlike pipe and tubing, hose sizes are designated by I.D. or inside diameter. Sizes are designated in 16ths of an inch by using a dash and a number equivalent to the numerator of the fraction.

Example is: dash 8 (-8) or 8/16" or half inch I.D.

Hose life can last a long time, but all rubber slowly deteriorates with contact from various substances, such as solvents, water, sunlight, heat, etc. Hoses are not as permanent as metal conductors and should be replaced every few years.

## NOTES

---

**Remember:**

*As inside diameter or I.D. is increased to reduce velocity, maximum system working pressure is decreased. This is due to the increase in surface area. A thicker wall (heavier schedule) may be required.*

*In standard pipe, the actual I.D. is usually larger than the nominal size quoted. A standard conversion chart should be used.*

Proper hose installation is critical. Improper bends, twisting, or lack of proper anchoring may lead to hose failure.

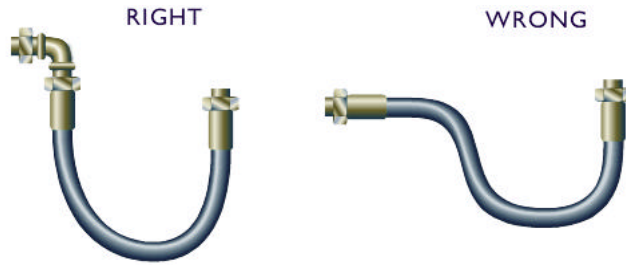

## Pipe

Steel pipe is often a preferred conductor from the standard point of performance and cost. However, it is often difficult to assemble, because welding is required to give maximum leak protection. It also requires costly flushing to insure a contaminant free system at startup.



Pipe is specified by its nominal outside diameter, but its actual flow capacity is determined by its inside area. For example, Schedules 40, 80, and 160 and Double Extra have the same outside diameter, and can be threaded by the same pipe die. The difference is the inside diameter and area. Schedule 40 pipe is standard and has the thinnest wall, with more flow area but less pressure rating.

NOMINAL SIZE	PIPE O.D.	INSIDE DIAMETER			
		SCHED. 40	SCHED. 80	SCHED. 160	DOUBLE EXTRA HEAVY
1/8	.405	.269	.215	--	--
1/4	.540	.364	.302	--	--
3/8	.675	.493	.423	--	--
1/2	.840	.622	.546	.466	.252
3/4	1.050	.824	.742	.614	.434
1	1.315	1.049	.957	.815	.599
1 1/4	1.660	1.380	1.278	1.160	.896
1 1/2	1.900	1.610	1.500	1.338	1.100
2	2.375	2.067	1.939	1.689	1.503
2 1/2	2.875	2.469	2.323	2.125	1.771
3	3.500	3.068	2.900	2.624	--
3 1/2	4.000	3.548	3.364	--	--
4	4.500	4.026	3.826	3.438	--
5	5.563	5.047	4.813	4.313	4.063

## Steel Tubing

Tubing is used as a conductor when rigid lines are required. It is often easier to assemble and form and requires no welding to achieve leak-free connections. As with all types of conductors, certain requirements must be met. The line must be large enough to carry the required flow and strong enough to withstand internal pressures.



## NOTES

---



Tubing is measured and specified by its wall thickness and outside diameter. Pressure ratings are based on tubing grade and wall thickness. One piece of tubing is joined to another tube connector, or component, with a tube connector and fastening nut. Often the tube is pre-flared to 37 degrees to accept a 37 degree flare connector.

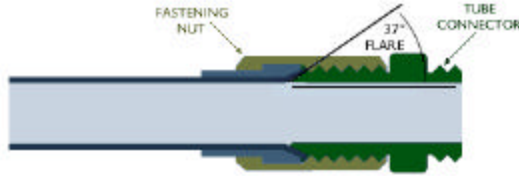

## Sizing

With this chart you will learn proper size selection for desired flow rate or velocity. To determine the pipe size needed, enter the flow in gpm and the velocity in feet per second in the windows labeled gpm and fps. You can also use your mouse to slide the red markers on either scale.

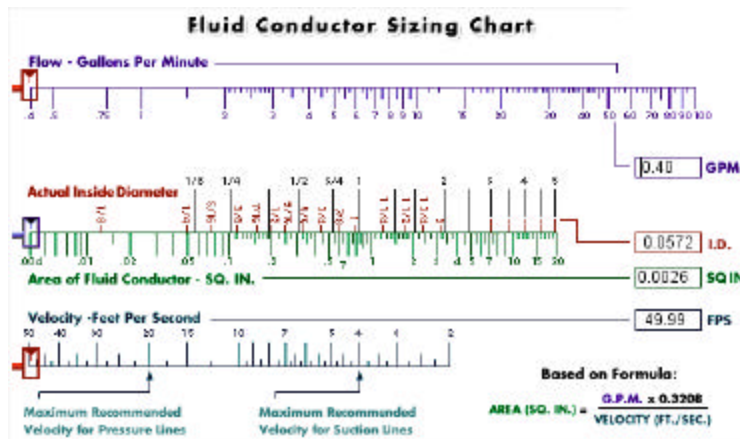

## Quiz

- As flow increases, fluid velocity through a conductor increases.
  - True
  - False
- Using standard nominal pipe with a flow of 27 1/2 gpm, what pipe size would give us 20 ft/sec velocity?
  - 1/2"
  - 3/4"
  - 1"
  - need to know I.D.
- Tubing is measured and specified by its wall thickness and its O.D.
  - True
  - False

## NOTES

---

# UNDERSTANDING SCHEMATICS

## Introduction

When hydraulic systems are designed, whether on paper or computer, the layout of the system is expressed in what is called a schematic. A schematic is a line drawing made up of a series of symbols and connections that represent the actual components in a hydraulic system. Although there are dozens of different symbols used in a complex schematic drawing, it is important to be able to recognize several basic symbols. In this section, you will learn to identify these basic symbols as well as where they are placed in the schematic of a basic hydraulic system.

## Symbolism

Symbols are critical for technical communication. They are not dependent on any specific language, being international in scope and character. Hydraulic graphic symbols emphasize the function and methods of operation of components. These symbols can be rather simple to draw, if we understand their logic and the elementary forms used in symbol design. The elementary forms of symbols are: circles, squares, triangles, arcs, arrows, dots, and crosses.

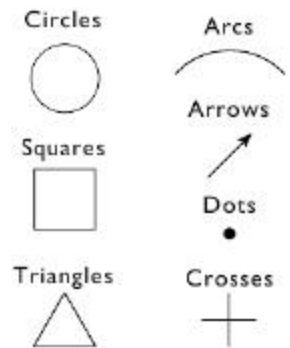



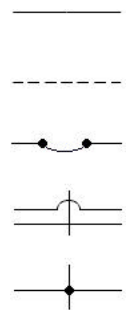

## Lines

Understanding graphic line symbols is critical to proper interpretation of schematics. Continuous lines indicate a working line, pilot supply, return, or electrical line. A dashed line indicates a pilot, drain, purge, or bleed line. Flexible lines indicate a hose usually connected to a moving part. Lines crossing may use loops at crossovers or be straight across. Lines joining may use a dot at the junction or can be at right angles.



## Reservoirs

-  Reservoirs that are vented are shown as a rectangle with the top line omitted.
-  Pressurized reservoirs are shown as a capsules. Reservoirs may have fluid oil lines terminating above or below the fluid level. The above oil level return line terminates at or slightly below the upright legs of the tank symbol. The below level return line touches the bottom of the tank symbol. A simplified symbol to represent the reservoir, minimizes the need to draw a number of lines returning to the reservoir. A number of these in the same circuit will represent a common reservoir. These symbols have the same function as the ground symbol in electric circuits.
- 
- 
- 

## NOTES

---

*Using your hydraulic symbols template properly draw the following symbols:*

*Pressure compensated pump*

*Gear Pump*

*Flow control with reverse flow check (adjustable)*

*Pressure compensated flow control (adjustable)*

*Four-way, three-position, open centered, solenoid operated directional control valve.*

## Pumps

Rotary devices are shown as a circle. Pumps having a energy triangle pointing to the outside perimeter, indicate the energy is leaving the component. A sloping arrow drawn diagonally through the circle indicates that the pump is variable, or the output flow can be regulated without changing shaft speed.

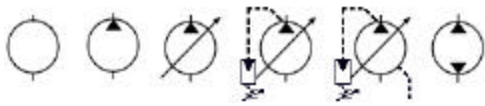

A sloping arrow drawn diagonally through the circle indicates that the pump is variable, or the output flow can be regulated without changing shaft speed. A control symbol with a energy triangle that is connected to an adjustable spring indicates that the pump is pressure compensated. Some types of pumps have internal

leakage that is returned to the tank by a case drain. This is indicated with a drain line drawn leaving the circle. Pumps that are bi-directional are shown with two energy flow triangles.

## Flow control

The symbol for a flow control valve begins with an upper and lower arc. This would symbolize a fixed orifice. An arrow drawn sloping through the arcs indicate that the orifice is adjustable. This would be the graphic symbol for a needle valve. When we add an arrow to the flow line inside a control box, we have indicated that the valve is pressure compensated or true flow control. A flow control valve with a check valve indicates reverse flow around the valve.

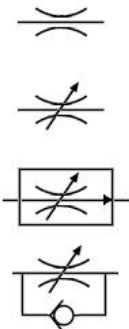

## Directional Control Valves

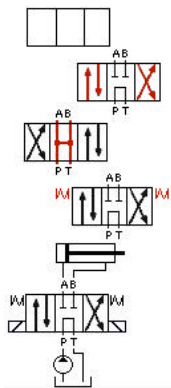

The symbol for directional control valve has multiple envelopes showing the number of positions the valve may have. A three-position directional control valve is shown with three envelopes. Arrows in each envelope indicate the possible direction and flow while the valve is in that position. The center position in a three-position directional control valve is designed according to the type of circuit or application. This centered position indicates the flow path of the fluid while the valve is centered. While there are many types of center configurations, the four most common are tandem, closed, float, and open. To shift the valve or activate it, we can use a mechanical handle or lever, an electric solenoid or hydraulic pilot pressure. The springs on both sides of the symbol indicate that the valve is centered when not activated. In

position one, or centered, fluid flows from the pump, through the valve to the tank. This is a tandem center. When we shift the valve to position two, fluid now flows from P to A, extending the cylinder, shifting to position three, which shows flow now from P to B and from A to T, the cylinder retracts.

## NOTES

---

*Using your hydraulic symbols template properly draw the following symbols:*

*Hydraulic motor (bi-directional)*

*Pilot operated check valve (pilot to open)*

*Double acting cylinder*

*Hydraulic filter with a bypass check valve*

*Hydraulic oil cooler.*

## Pressure Valves

The symbol for a pressure valve begins with a single envelope. The arrow in the envelope depicts the direction of flow through the valve. The ports are indicated as 1 and 2, or primary and secondary. Flow through the valve is from the primary to the secondary port. Notice that in the normal position, the arrow is not aligned with the port. This indicates that

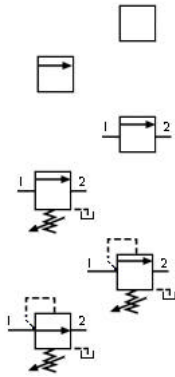

the valve is normally closed. All pressure valves are normally closed with the exception of a pressure reducing valve, which is normally open. The spring located perpendicular to the arrow indicates that the spring force holds the valve closed. An arrow diagonally through the spring indicates that the spring force is adjustable. Pilot pressure opposes spring force. This is indicated by the dotted line running from the primary port perpendicular to the arrow opposite the spring. When the hydraulic pressure piloted from the primary port exceeds the force of the spring, the valve moves to the open position, aligning the primary and secondary ports.

## Check valves

Check valve symbols are drawn with a small circle inside an open triangle. Free flow is opposite the direction the triangle is pointed. As the circle moves into the triangle, the flow is blocked or checked. Check valves may be piloted to open or to closed. Pilot to open is indicated with a pilot line directed to the triangle shown to push the circle away from the seal. Pilot to closed is indicated by directing the pilot line to back of the circle or into the seat.

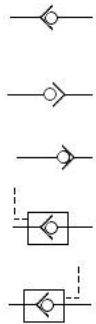

## Motors

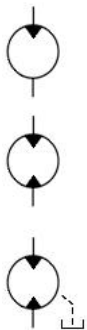

Hydraulic motor graphic symbols are opposite of hydraulic pumps', the difference being the energy triangle points into the circle, indicating fluid energy entering. Two energy triangles pointing in indicate a bi-directional or reversible motor. As with pumps, many hydraulic motor designs have internal leakage. A dotted line leaving the circle indicates a drain line to the tank.

## NOTES

---



## Cylinders

Fluid power cylinders with no unusual relationship between the bore and rod size are shown: single acting, double acting, and double rod. An internal rectangle adjacent to the symbol for the piston indicates a cushion device at the end of the stroke. If the diameter of the rod is larger than usual for the bore size, the symbol must reflect this.

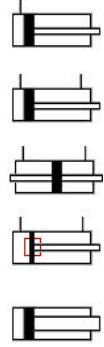

## Filters



The graphic symbol for a hydraulic fluid conditioned device is shown with a square standing on end. A dotted line across opposite corners indicates that it is a filter or a strainer. Adding a check valve across and parallel to the ports indicate that the filter has a bypass.

## Heat exchanger



Hydraulic heat exchangers may be considered coolers or heaters. Their graphic symbols are often confused. As with a filter, the base symbol is shown as a square on end. Inside arrows pointing in indicate the introduction of heat or a heater. Arrows pointing out indicate heat dissipating or a cooler. Arrows both pointing in and out would indicate a temperature controller or temperature that is maintained between two predetermined limits.

## NOTES

---

*Using your hydraulic symbols template properly draw a simple “closed center circuit.”  
For review, see “animation’ under directional control “open vs closed center”.*

*NOTE: If you choose to draw a motor circuit, insure that the proper directional control  
center configuration is selected.*

---

## Quiz

1. Identify the following symbols:

- a) Relief valve
- b) Counterbalance valve
- c) Sequence valve

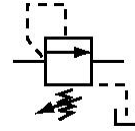

2. Identify the following symbols:

- a) Needle valve
- b) Throttling valve
- c) Pressure compensated flow control valve

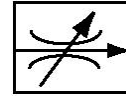

3. Identify the following symbols:

- a) Gear pump
- b) Piston pump
- c) Pressure compensated pump

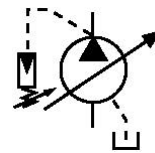

## NOTES

---

*Using your hydraulic symbols template properly draw a simple “High-Low circuit.”*

*Use Circuit #2 from understanding schematics section as a guide.*

## Circuit #1

A schematic is a compilation of graphic symbols, interconnected, showing a sequence of operational flow. In short, they explain how a circuit functions. Correct schematic reading is the most important element of hydraulic troubleshooting. Although initially most circuits may appear complicated, recognizing standard symbols and systematic flow tracings simplifies the process.

This circuit uses two sequence valves. They are normally closed valves that open at a predetermined setting. By tracing the flow in this circuit, we should be able to determine how this circuit is designed to operate. This process is called reading a schematic. Let's begin at the pump.

Follow the flow past the relief valve to the directional control valve which is shifted to the upper position, as shown. The directional control valve directs flow to the lines in the upper circuit. Here, flow can go three places. The upper check valve blocks one passage. The closed sequence valve blocks another, but flow to the A port of the actuator is open. As the cylinder rod retracts, flow from the B port is blocked at the check valve, so it exits to the tank through the directional control valve.

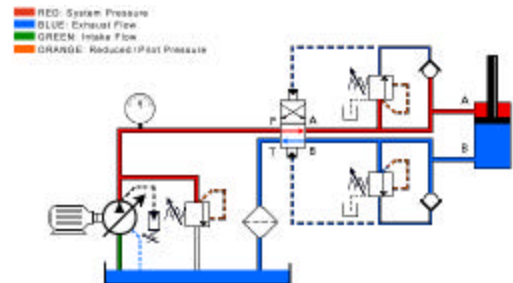

When the cylinder is fully retracted, pressure will build in the pilot passage of the sequence valve. It opens and sends pilot pressure to the directional control valve. Pilot pressure on the upper side of the directional control valve will shift the valve downward. Pump flow is now directed to the lower circuit and the flow here goes to three places. It is blocked at the check valve and blocked at the closed sequence valve, but flow to the B port of the actuator is open. Flow in the port will apply pressure to the piston and extend the cylinder. Flow out of the A port is blocked by the upper check valve, so it flows through the directional control valve to the tank.

When the cylinder is fully extended, pressure continues to build. Pilot pressure opens the sequence valve on the bottom. This sends pilot pressure to the lower side of the directional control valve shifting it back into the upper position. Now, pump flow is once again directed to the rod side of the actuator to retract the cylinder, and the cycle begins once again.

Tracing the flow in this circuit reveals that it is designed to keep retracting and extending automatically. Now that we understand the circuit we may conclude that the proper function of the system will depend on the proper setting and function of the sequence valves and the proper function of the hydraulically piloted directional control valve.

## NOTES

---

*Counterbalance valves may not require a pilot operated check valve in the circuit if they are specified as zero leakage.*

*Using your hydraulic symbols template properly draw a hydraulic circuit with a counterbalance valve.*

*Use Circuit #3 from understanding schematics section as a guide.*

## Circuit # 2

This is a High-Low circuit. Such a circuit would be used to achieve high speed or rapid advance at low pressure, followed by slow speed and high force. A good example of a High-Low system would be a press where the ram would rapidly advance up to the work piece. At that time, the pressure starts to build. The flow from the high volume pump is diverted to the tank. The low volume pump would produce the little flow needed to continue moving the ram into the work piece. The pressure will continue to rise until it reaches the relief valve setting. When the directional control valve is reversed, the pressure drops and the unloading valve closes. The cylinder would retract at a rapid speed.

Now let's examine more closely the components that make up this system. First, the unloading valve. This valve has been set at 500 psi. When the system pressure reaches 500 psi, this valve will open and allow the flow from the high volume pump to go back to the tank at minimal pressure.

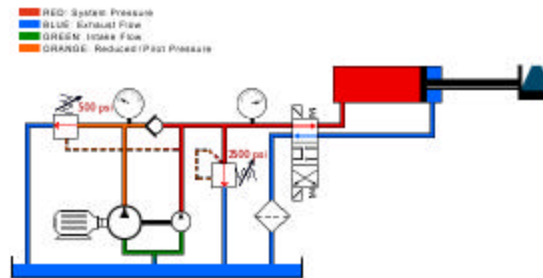

Next, we will look at the function of the check valve. When the system pressure is less than the unloading valve setting, flow from the high volume pump flows through the check valve to combine with the flow from the low volume pump. After the unloading valve opens, this check valve closes, so that the flow from the low volume pump won't flow to the unloading valve.

Now, let's take a look at the High-Low pump group. This is a double pump. These pumps have a common inlet and separate outlets. During low pressure rapid advance, both pump flows are combined. When the unloading valve opens, the large pump's flow returns to the tank and the small pump's flow is used to do the work.

Finally, we will look at the system's pressure relief valve. This valve limits the maximum system pressure. Notice the schematic shows the pressure at which the valve should be set. Now, watch as these components work.

## NOTES

---



### Circuit #3

In our circuit, the cylinder has a weight that would cause it to free fall or drop at an uncontrolled rate. A counterbalance valve is placed in the rod end port of the cylinder to apply back pressure. The back pressure is the result of the load trying to force the fluid out of the cylinder and through the counterbalance valve, which is closed. The counterbalance valve has to be set slightly above the load-induced pressure. When shifted, the directional control valve applies pressure on the cylinder piston. This in turn increases the back pressure, causing the counter balance valve to open, allowing the cylinder to lower the load at a controlled rate.

Now let's examine more closely the components that make up this system. First, we'll look at the off-line or kidney loop filter circuit. This circuit consists of a pump motor group, a filter, and an air-to-oil heat exchanger. The pump draws hydraulic fluid from the reservoir, passing the fluid through a filter and an air-to-oil heat exchanger. This circuit usually runs continually to keep the hydraulic fluid clean and cool. Next is the pressure compensated pump. The pressure compensated pump de-strokes when the directional control valve is centered. At this time, there is pressure being maintained between the pump and directional control valve, but no flow. When the directional control valve is shifted, the pump goes on stroke, providing flow for the circuit.

Next, we have the directional control valve. This is a three-position, four-way valve with a float center. This valve, when centered, will block flow from the pump so that pressure will build and de-stroke the pump. Both work ports are routed back to the tank, so there is no pressure in the work port lines, except between the rod end of the cylinder and the counterbalance valve.

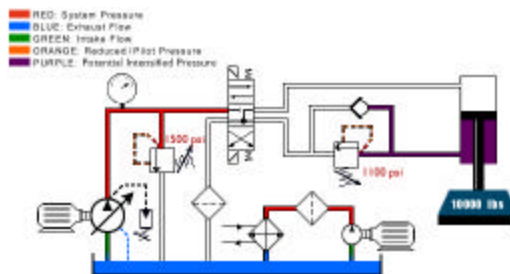

Now, we look at the counterbalance valve. The counterbalance valve maintains back pressure on the rod side of the cylinder so that the cylinder brings the load down at a controlled rate of speed. The check valve is used to lock and hold the load on the cylinder when the directional control valve is centered. Now, let's watch the system work again and see how each component operates.

## NOTES

---

## SYSTEM DESIGN

### Power Unit

#### View #1

##### 1. Fan cooled heat exchanger

Connected in series to the off-line re-circulation loop  
Provides cooling for main hydraulic reservoir  
System temperature not to exceed 160 degrees Fahrenheit

##### 2. Off-line re-circulation pump and motor

Three horsepower electric motor  
15 gpm gear type hydraulic pump  
Provides flow for the re-circulation loop

##### 3. Off-line re-circulation filter

Connected in series to the off-line re-circulation loop  
10  $\mu$ m pressure filter  
Spin-off housing  
Off-line filtration

##### 4. System pressure line filter

Connected in line and downstream from  
main hydraulic pumps  
10  $\mu$ m filter  
Provides filtration protection for proportional  
valve on the motor drive manifold

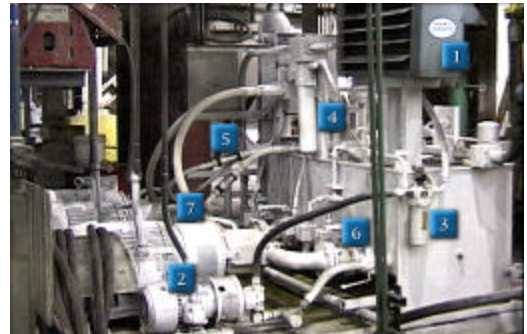

##### 5. Flow meter

Installed in the main pump case drain lines  
0-10 gpm monitoring  
Provides case drain flow monitoring to determine internal wear  
Case flow should not exceed 5 gpm

##### 6. Shut-off valve and pump suction line

Installed between reservoir and suction port of pump  
Swing valve design with locking handle  
Closes reservoir flow during pump change out

##### 7. Main pump

45 gpm at 1750 rpm  
Axial piston pressure compensated  
Provides system flow  
Compensator set at 1500 psi

## NOTES

---

## View # 2

### 1. System accumulators

- 5 gallon accumulator pre-charged to 450 psi
- 10 gallon accumulator pre-charged to 450 psi
- Provides stored energy in the event of input power loss

### 2. Accumulator bleed off and isolation valves

- Ball valve design, normally closed
- Used to bleed down and isolate accumulators for maintenance or repair

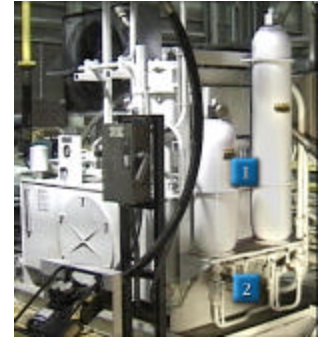

## View # 3

### 1. System reservoir

- 150 gallon reservoir
- Provides oil storage for main system power unit

### 2. Reservoir breather

- 5  $\mu\text{m}$
- Spin-on element
- Provides filtration protection for vented system reservoir

### 3. System pressure gauge

- 0-3000 psi
- Glycerin filled
- Used to measure main system pressure relief and pump compensators

### 4. System return line filter

- 10  $\mu\text{m}$  element
- Bolted cover for element removal
- Provides main source of contamination control for hydraulic system

### 5. Reservoir clean out cover

- Provides access to clean out the reservoir
- Bolted with Buna seal

### 6. Level indicator

- Sight glass designed with thermometer
- Provides visual indication of fluid level
- Do not fill reservoir past top glass

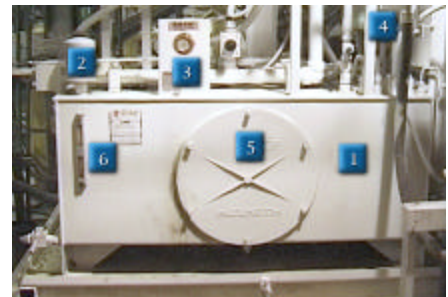

## NOTES

---

## View #4

### 1. Manifold assembly

Ductile iron  
6000 psi rated

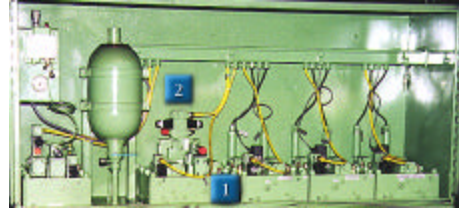

### 2. Multi-valve 4 station valve stack

#### 1. Pilot Valve

Size 6 directional control valve  
Float center  
Shifts size 25 directional control valve

#### 2. Flow control valve

Size 6 sandwiched configured  
Controls shift speed of size 25 directional control valve

#### 3. Directional control valve

Size 25  
Starts, stops, and changes direction of flow to hydraulic cylinder

#### 4. Check valve

Pilot operated  
Locks cylinder in position

#### 5. Pilot valve

Size 6 directional control  
Pilot opens check valve

#### 6. Pressure reducing valve

Size 16, three-way reducing valve  
Reduces pressure to piston side of hydraulic cylinder

#### 7. Pilot valve

Size 6 pressure reducing valve  
Pilot control for size 16 pressure reducing valve



## NOTES

---



# Build a System

## System 1

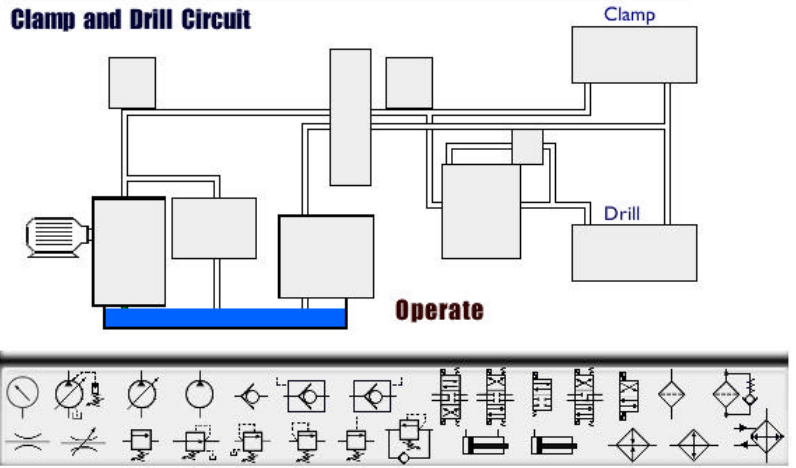

## System 2

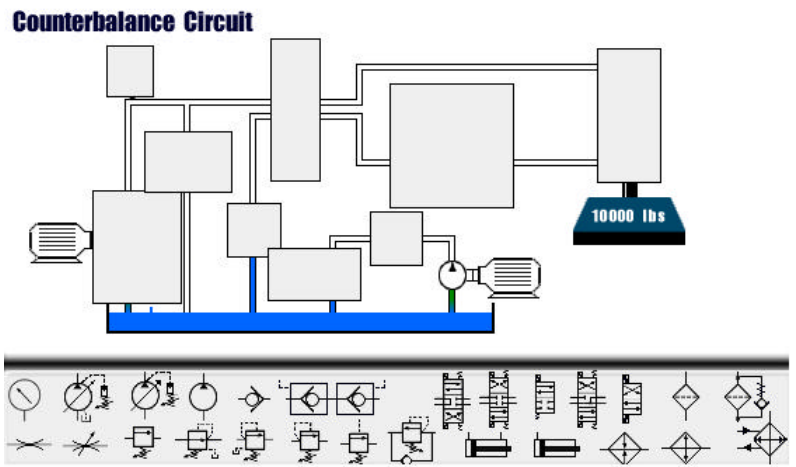

## System 3

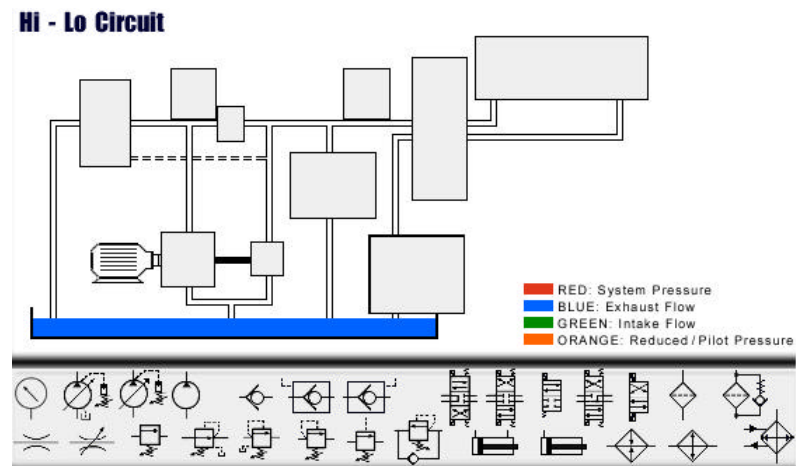

## NOTES

---

## NOTES

---

## NOTES

---